

Surtech

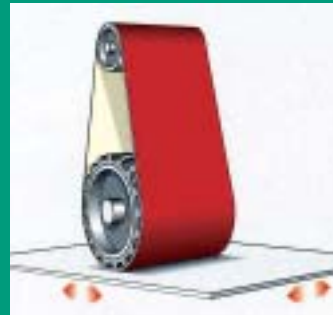

Abrasive Belts and Contact  
Wheels for Grinding,  
Deburring and Polishing

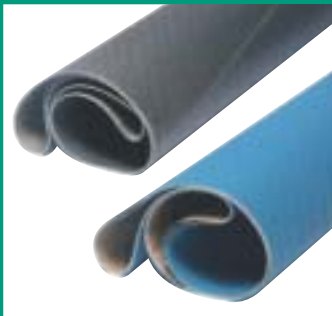

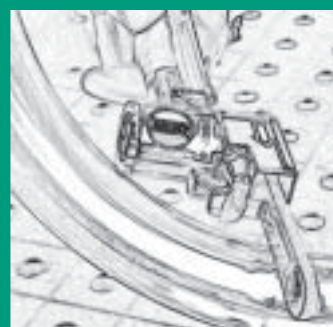

# Abrasive Belts and Contact Wheels

## CONTENTS

### INTRODUCTION

This catalogue helps you find the benchmark abrasive belt for your machine and application.

The recommendations are in two parts:

Pages 3 to 10 list abrasive belt grades which we consider amongst the best of their type. Under each belt grade we show the machine type for which it is best suited.

Pages 11 to 20 list most abrasive grinding, deburring and polishing machines. Under each machine type we show the abrasive belt grade we recommend for this machine.

If you are interested in more background information about coated abrasives, see pages 20 to 26 and for the correct choice of contact wheels pages 26 to 30.

### THE ABRASIVE BELT GRADES

Aluminium oxide belts	3
Silicon carbide belts	3
Zirconia belts	4
Ceramic belts	4
Compact grain belts	5
Structured and engineered abrasive belts	5
Cork belts	6
Cubic boron nitride belts	7
Flexible diamond abrasive	7
Microabrasives	8
Abrasive impregnated non woven nylon	9
Polishing belts	9
Speciality abrasive belts	10

### THE MACHINES

Portable abrasive power tools	11
Bench and pedestal grinders	13
Notchers	16
Microfinishers	16
Tube grinders	16
Tool post grinders	17
Floor and swing grinders	17
Power grinders	17
Flatbed throughfeed machines	18
Overhead belt grinders	19



### GENERAL

Abrasive belt information	20
Contact wheels	26



## OUR BENCHMARK ABRASIVE BELT GRADES

### INTRODUCTION

The choice of abrasive belts is vast and can be confusing and overwhelming even for those working in the industry

We have therefore selected a range of belts which are particularly well suited to the machines shown from page 11 onwards.

These belts have during tests performed consistently above average. They also represent excellent value for money.

Start with our recommendation and then run your own comparison tests until you find a belt that in your opinion performs even better.

SURTECH are totally independent and do not promote one manufacturer's belts in preference to another.

### ALUMINIUM OXIDE BELTS



**A12 O3**  
Synthetically made Aluminium Oxide. (9.4 on the Mohs scale of hardness).

Tough and wedge shaped without excessive fracturing or shedding. General purpose belts for grinding, deburring and finishing.

Available in more variations and grits than any other mineral but not necessarily the best choice for every grinding operation. See alternatives below.

Available in grit sizes from 24 to 1200.

Since zirconia and ceramic belts are only available up to grit 120 the aluminium oxide belt is often your only choice for finer grits.

### ALUMINIUM OXIDE SINGLE GRAIN PRODUCTS

#### VA1

**Mineral and Product Name:**  
Aluminium Oxide KK511 F

**Grit range:** 60 - 800

**Backing/Weight:**  
Very flexible cotton cloth. F weight.

**Applications for aluminium oxide belts:**  
Unalloyed and low alloyed steels, brass castings, bronze, zinc castings, with highly contoured surfaces.

**Recommended contact wheel shore hardness:**  
20 - 45 shore. *See page 26.*

**Recommended for use on the following machines:**  
BG10 - Standard Backstands, *see page 15.*

#### VA2

**Mineral and Product Name:**  
Aluminium Oxide KK 511 J

**Grit range:** 60 - 400

**Backing/Weight:**  
Flexible cotton cloth. J weight.

**Applications:**  
Unalloyed and low alloy steel, brass, bronze, zinc. Will conform well to moderately contoured surfaces.

**Recommended contact wheel shore hardness:**  
35 - 60 shore, *see page 26.*  
Smooth or with PUR flaps, *see page 26.*

**Recommended for use on the following machines:**  
BG10 - Standard Backstands, *see page 15,*  
BG3 - 4 Wheel machines, *see page 14,*  
BG8 - 411, 704, 491, *see page 15.*

#### VA3

**Mineral and Product Name:**  
Aluminium Oxide Stearate coated to prevent clogging KK532F

**Grit range:** 80 - 600

**Backing/Weight:**  
Very flexible cotton. F weight.

**Applications for aluminium oxide belts:**  
Low alloy steel, aluminium, brass, bronze, zinc with highly contoured surfaces.

**Recommended contact wheel shore hardness:**  
20 - 45 shore, *see page 26.*

**Recommended for use on the following machines:**  
BG10 - Standard Backstands, *see page 15.*

#### VA4

**Mineral and Product Name:**  
Aluminium Oxide KK711X

**Grit range:** 24 - 400

**Backing/Weight:**  
Polyester cloth from grit 24 to 80. Cotton cloth from grit 120 to 400. X weight.

**Applications for aluminium oxide belts:**  
Unalloyed and low alloy steels, aluminium, brass, bronze, iron castings with flat surfaces. One of the best general purpose belts.

**Recommended contact wheel shore hardness:**  
60 - 80 shore, *see page 26.*

**Recommended for use on the following machines:**  
BG1 - Bench Grinders, *see page 13.*  
BG2 - Slack of Belt, *see page 13.*  
BG3 - Edge Deburrers, *see page 14,*  
BG4 - 4 Wheel machines, *see page 14.*



**Gritty says . . .**

*Soft belts grades F and J must be used with soft contact wheels between 20 and 45 shore. Stiff belt grades Z, Y and X must be used with harder contact wheels 45 to 80 shore.*

### SILICON CARBIDE SINGLE GRAIN PRODUCTS

**Si C**  
Synthetically made Silicon carbide. 9.6 on the Mohs scale of hardness. Another classic mineral.

Hard and sharp, but very brittle. Best used with light contact pressure. Wears and fractures fast. Often used on non ferrous metals, titanium, magnesium, plastics, glass (arising machines), rubber, stone, primer, sealer, topcoats.

When used on stainless steel it produces a unique bright and even finish. It is particularly well liked for hygienically clean and corrosion free stainless steel surfaces for the catering industry. Available in grits from 24 to 600.



**Gritty says . . .**

*Silicon carbide belts produce a brighter (with a blue tint) and lower Ra finish on stainless steel than aluminium oxide belts. These belts are also recommended for finishing aluminium sheet.*

#### VS1

**Mineral and Product Name:**  
Silicon Carbide, Waterproof CK721X.

**Grit range:** 24 - 600

**Backing/Weight:**  
Waterproof polyester cloth from grit 24 to 180. Cotton cloth from grit 220 to 600. X weight.

**Applications for silicon carbide belts:**  
Unalloyed and low alloy steels, cast irons, titanium alloys, carbide coatings, brass, bronze. For cylindrical and flat parts.

**Recommended contact wheel shore hardness:**  
60 - 80 shore. *See page 26.*

**Recommended for use on the following machines:**  
BG10 - Standard Backstands, *see page 15,*  
FLAT 2 - Throughfeed machines, *see page 18.*  
CENT 2 - Centreless machines, *see page 17.*

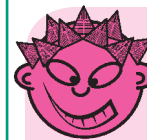

**Gritty says . . .**

*Abrasive belts grind faster, finish finer, work faster and safer than other cutting tools.*

### SILICON CARBIDE / CORK MIXTURE PRODUCTS (SUPERFINISHING)

#### VSC1

**Mineral and Product Name:**  
Silicon Carbide/cork mixture CK917C.

**Grit range:** 800

**Backing/Weight:**  
Robust cotton. X weight.

**Applications for silicon carbide cork belts:**  
Unalloyed and low alloy steels, chrome and chrome nickel steels. For cylindrical and flat parts. Superfinishing.

**Recommended contact wheel shore hardness:**  
45 - 60 shore. *See page 26.*

**Recommended for use on the following machines:**

FLAT 2 - Throughfeed machines, see page 18.

CENT 2 - Centreless machines, see page 17.



## Gritty says . . .

*Abrasive belts are safe. Unlike grinding wheels they quickly loose their kinetic energy when they break. (used properly, belt breaks are extremely rare).*



## Gritty says . . .

*Abrasive belts come with many cloth grades from very flexible to very stiff. You need to use soft contact wheels with flexible backings and hard contact wheels with stiff backings.*

## ZIRCONIA SELF SHARPENING SINGLE GRAIN PRODUCTS



Also called zirconia alumina, made by alloying oxides of zirconium and aluminium. (Fine crystalline STRUCTURE grain consisting of aluminium oxide and zirconium oxide.

Slightly lower hardness but higher toughness than aluminium oxide.

Zirconia needs higher contact pressure than aluminium oxide. Low contact pressure will result in glazing.

Introduced into Coated Abrasives during the mid 1960's when it was developed for high stock removal operations under high contact pressures and with coarse grits. Now mainly recommended as the standard mineral for grinding, graining and finishing of stainless steel.

Zirconia has a self sharpening characteristic which gives it longer life on harder metals.

Zirconia belts are only available in grits 36 to between 80 and 120. For finer grits you will have to revert back to aluminium oxide belts. The exception being grade ZK713X under VZ1 below.

The zirconia mineral is usually mixed with aluminium oxide. The zirconia content can vary. A higher zirconia content does not necessarily give better results if the right contact pressure cannot be applied and the wrong contact wheel is used.

### VZ1

**Mineral and Product Name:** Zirconia. Slightly open coated. Self sharpening. ZK713X.

**Grit range:** 24 - 240

**Backing/Weight:** Polyester cloth from grit 24 to 150. Cotton cloth from grit 180 to 240. X weight.

**Applications for zirconia belts:** Unalloyed and low alloy steels, cast irons, aluminium alloys, brass, bronze. For cylindrical and flat parts.

**Recommended contact wheel shore hardness:** 45 - 80 shore. See page 26.

**Recommended for use on the following machines:**

PORT1 - Belt Files, see page 11.

BG1 - Bench Grinders, see page 13.

BG2 - Slack of Belt Edge Deburrers, see page 13.

BG3 - 4 Wheel machines, see page 14.

BG4 - Vertical Grinders, see page 14.

BG5 - Linishers, see page 14.

BG6 - Edge and Corner Grinders, see page 14.

BG7 - Corner Grinders, see page 14.

BG9 - Belt Grinders, see page 15.

BG10 - Standard Backstands, see page 15.

BG12 - Notchers, see page 16.

BG14 - Floor and Swing Grinders, see page 17.

FLAT5 - Slag Grinders, see page 18.

FLAT9 - Overhead Belt Grinders, see page 19.

### VZ2

**Mineral and Product Name:** Zirconia. With top size. Self sharpening. ZK744X.

(Higher zirconia content than ZK713X plus top size additives for cooler grinding and longer life). The top size is of particular benefit for grinding heat sensitive alloys such as austenitic stainless steel.

**Grit range:** 24 - 80

**Backing/Weight:** Polyester cloth. X weight.

**Applications for zirconia belts:** Chrome and chrome nickel steels, high alloy steels, nickel alloys.

**Recommended contact wheel shore hardness:** 60 - 80 shore. See page 26.

**Recommended for use on the following machines:**

PORT2 - Belt Files, see page 11.

PORT4 PR Bent Tube Finisher, see page 12.

BG5 - Linishers, see page 14.

BG6 - Edge and Corner Grinders, see page 14.

BG7 - Corner Grinders, see page 14.

BG9 - Bench Grinders, see page 15.

BG10 - Standard Backstands, see page 15.

BG12 - Notchers, see page 16.

CENT2 - Centreless machines, see page 17.

CENT3 - Tool Post Grinders, see page 17.

FLAT1 - Throughfeed Edge Deburrer, see page 18.

FLAT2 - Narrow Throughfeed machines, see page 18.

FLAT3 - Wide Belt machines, see page 18.

### VZ3

**Mineral and Product Name:**

Zirconia (very high zirconia content). With top size grinding additive. KK815Y.

**Grit range:** 36 - 100

**Backing/Weight:** Polyester cloth. Y weight.

**Applications for zirconia belts:** Chrome and chrome nickel steels, high alloy steels, nickel alloys. For high contact pressure.

**Recommended contact wheel shore hardness:** 60 - 80 shore. See page 26.

For Power Grinders 90 shore or even steel faced contact wheels. See page 26.

**Recommended for use on the following machines:**

BG11 - Heavy Duty Backstands, see page 15.

BG14 - Floor and Swing Grinders, see page 17.



## Gritty says . . .

*Abrasive belts are available in grit sizes from very coarse 24 to ultrafine 2500.*

## CERAMIC PRODUCTS



Also called Ceramic Aluminium Oxide or Seeded Gel\* (Norton trade mark) or Cubitron\* (3M trade mark).

Ceramic grain is very hard and very tough. Harder and tougher than conventional brown aluminium oxide and zirconia. Hardness on the Mohs scale approx. 9.5.

With ceramic aluminium oxide small micron size particles break off all the time to expose new cutting edges. It is two to three times tougher to fracture than aluminium oxide and lasts considerably longer than any other mineral on all operations requiring high to extra high contact pressures (some claim 500% compared to aluminium oxide and 300% compared to zirconia).

Ceramic belts need careful tuning of the machine, contact wheel, contact pressure and speed to get full benefits out of them. Despite their high price ceramic belts are the most effective and most economical choice for many grinding operations. Grits 24 to 120.

Like zirconia they are available as a blend with other minerals. The higher the ceramic content, the tougher the belt and in theory at least the longer the belt life, as long as you can apply the high contact pressures that are necessary to break the mineral down, thus keeping it sharp.

Ceramic belts are self sharpening. Some grades have a top size to aid cutting high nickel and titanium alloy steels and to keep temperatures down.



## Gritty says . . .

*Next to diamond and cubic boron nitride (CBN), ceramic is at present the toughest mineral finisher.*

### VCER1

**Mineral and Product Name:** Ceramic with top size grinding additive. Self sharpening. XK870X.

**Grit range:** 24 - 120

**Backing/Weight:** Polyester cloth. X weight.

**Applications for ceramic belts:**  
 Chrome and chrome nickel steels, high alloy steels, titanium alloys, nickel alloys, brass, bronze. For cylindrical and flat parts.

**Recommended contact wheel shore hardness:**  
 60 - 80 shore. *See page 29.*

**Recommended for use on the following machines:**  
 PORT1 - Belt Files, *see page 11.*  
 PORT2 - Belt Files, *see page 11.*  
 BG8 - Dedicated machines for Turbine Blades and Medical Implants, *see page 15.*

BG11 - Extra Heavy Duty Manual Abrasive Belt Grinders, *see page 15.*

PG1 - Power Grinders, *see page 18.*

FLAT2 - Narrow Throughfeed machines, *see page 18.*

FLAT5 - Slag Grinders, *see page 18.*

## VCER2

**Mineral and Product Name:**  
 Ceramic with top size grinding additive. Self sharpening. XK850X. Best for medium high contact pressure applications.

**Grit range:** 36, 40, 50, 60, 80

**Backing/Weight:**  
 Polyester cloth. X weight.

**Applications for ceramic belts:**  
 Chrome and chrome nickel steels, high alloy steels, nickel alloys. For cylindrical and flat parts.

**Recommended contact wheel shore hardness:**  
 60 - 80 shore. *See page 26.*

**Recommended for use on the following machines:**  
 PORT2 - Belt Files, *see page 11.*  
 PORT4 PR Bent Tube Linisher, *see page 12.*  
 FLAT9 - Overhead Belt Grinders, *see page 19.*



**Gritty says . . .**

*Structured, engineered and compact grain abrasive belts can reduce the number of steps in a finishing sequence.*

## COMPACT GRAIN PRODUCTS

Compact grain belts are aimed at the same market as structured or engineered belts listed below.



*Conglomerate Belts*

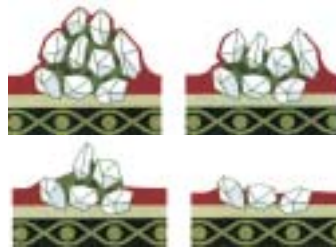

*Compact Grain Belts from new to worn*

Several manufacturers have developed conglomerate mineral belts and market them under a variety of registered trademarks. They all have in common that they have variously shaped clusters of abrasive minerals both aluminium oxide and silicon carbide. These clusters are in fact several layers of minerals, compared to the single layer of standard abrasives belts. This puts a larger amount of minerals on to a belt and as a result the belt has a considerably longer life.

Recommended for finishing rather than grinding. Will produce consistent fine finishes. Particularly recommended for pneumatic contact wheels. For tube finishing and for planetary bent tube finishing machines. Also for turbine blades and stainless steel parts. Grits 80 to 1200.

### VCA1

**Mineral and Product Name:**  
 Aluminium Oxide. Granulated compact grain. KK 772 J.

**Grit range:** 80 - 1200

**Backing/Weight:**  
 Flexible polyester cloth. J weight.

**Applications for compact grain belts:**  
 Unalloyed and low alloy steels, chrome and chrome nickel steel, high alloy steel, nickel alloys, titanium alloys, aluminium alloys, brass, bronze. For cylindrical, flat and contoured parts.

**Recommended contact wheel shore hardness:**  
 35 - 60 shore. *See page 26.*

**Recommended for use on the following machines:**  
 BG8 - Dedicated machines for Turbine Blades and Medical Implants, *see page 15.*  
 FLAT4 - Wide Belt Dedicated Graining machines, *see page 18.*  
 CENT1 - Planetary Abrasive Belt Tube Finishing machines, *see page 17.*

CENT3 - Tool Post Grinders, *see page 17.*

### VCA2

**Mineral and Product Name:**  
 Aluminium Oxide. Granulated compact grain. Self sharpening. KK 712 X.

**Grit range:** 80 - 600

**Backing/Weight:**  
 Polyester cloth. X weight.

**Applications for compact grain belts:**  
 Unalloyed and low alloy steels, chrome and chrome nickel steel, nickel alloys. For cylindrical and flat parts.

**Recommended contact wheel shore hardness:**  
 60 - 80 shore. *See page 26.*

**Recommended for use on the following machines:**  
 FLAT2 - Narrow Throughfeed machines, *see page 18.*  
 FLAT3 - Wide Belt machines, *see page 18?*

## VCS1

**Mineral and Product Name:**  
 Silicon Carbide. Granulated compact grain. CK 918X.

**Grit range:** 400 - 1200

**Backing/Weight:**  
 Polyester cloth. X weight.

**Applications:**  
 Unalloyed and low alloy steels, chrome and chrome nickel steel, high alloy steels, titanium alloys. For cylindrical and flat parts.

**Recommended contact wheel shore hardness:**  
 60 - 80 shore. *See page 26.*

**Recommended for use on the following machines:**  
 CENT2 - Centreless machines, *see page 17.*  
 FLAT2 - Narrow Throughfeed machines, *see page 18.*



**Gritty says . . .**

*Abrasive belts can grind materials which cannot be ground with other cutting tools.*

## STRUCTURED AND ENGINEERED ABRASIVE PRODUCTS



*3D Brick pattern*

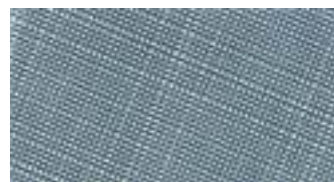

*3D Pyramid pattern*



*Close ups of Engineered and Structured Belts*

One of the more recent additions to the coating techniques of abrasive belts.

The abrasive minerals are bonded to the backing by precise three dimensional structures. Because these three dimensional structures contain many more abrasive minerals than conventional coated abrasives they last longer and produce much more consistent finishes.

Available in grades A300 to A6. (but no one grade is available in the whole grit range). The grit numbers for Engineered and Structured belts are different from those used for standard abrasive belts. The grit numbers for Compact Grain Belts are the same as for standard abrasive belts but produce a slightly coarser finish.

Structured & Engineered belts grit	Standard abrasive belt grit number
A300	P80
A160	P120
A110	P180
A100	P180 / 220
A90	P220
A80	P220/240
A65	P280
A60	P280/320
A45	P400
A30	P600 / 800
A16	P800 / 1200
A6	P2500

Engineered and Structured belts produce the finest finish yet possible with an abrasive belt, but they still cannot produce reflective mirror finish.

In a belt grinding sequence, engineered belts often need fewer steps than conventional belts.

Compact grain belts also produce finishes finer than conventional belts, but so far they are only available up to grit 1200.

Engineered and structured belts reduce the number of steps in a traditional belt sequence from coarse to fine. Typically a 5 step sequence can be reduced to a 3 step sequence.

Such performance is particularly important for multi head machines as used for finishing tubes and hollow sections.

With fewer belt sequences, machines need fewer heads. Fewer heads considerably reduces the cost of a machine when you consider that a head can cost £15,000 to £20,000.

For a rough guide of the microinch finishes you can expect from the

various engineered and structured belt grades on selected metals see page ??.

For a rough guide of stainless steel finishes in Ra microns you can expect from engineered and structured belts see page ??.

Despite their high price, engineered and structured belts can bring you considerable savings from longer life and shorter finishing sequences.

#### Applications for engineered and structured belts:

For all finishing operations with a multi-grit sequence. Engineered belts often allow you to reduce the number of steps for a sequence.

Will produce finishes finer than any other abrasive belt, close to a mirror finish.

Recommended for finishing parts that are plated.

If you need a reflective mirror finish, you must use polishing buffs or cotton or felt polishing belts.

*For polishing buffs see separate catalogue.*

*For polishing belts see page 9.*



### Gritty says . . .

*Abrasive belts with top size reduce clogging and cut cooler.*

*Titanium alloys designed for aerospace applications are extremely difficult to grind. Although the high strength of these alloys is a major cause of poor grindability, chemical adhesion of the titanium to the abrasive grain is also a factor contributing to poor abrasive performance. These difficulties can be alleviated by proper choice of grinding fluid.*

*Save money by not buying the cheapest but most efficient and economical abrasive belts.*

#### MSTR1

**Mineral and Product Name:** Aluminium Oxide with grinding aid, for dry operation. 3D Pyramid pattern. 217EA.

**Grit range:** A100 - A6

**Backing/Weight:** Flexible J-weight.

**Contact wheel:** 45 shore and softer.

**Applications:** Low pressure manual operations. Belt Grinders. Best choice for first time users of Trizact belts.

**Recommended for use on the following machines:**

PORT3 - Electric Roto-File, see page 11,  
PORT4 - Roto-Belter Flex, see page 12,

BG8 - Dedicated machines for Turbine Blades and Surgical Implants, see page 15,  
BG10 - Standard Backstands, see page 15,  
CENT1 - Planetary Abrasive Belt Tube Finishing machine, see page 17,

CENT2 - Centreless Grinders, see page 17,  
CENT3 - Tool Post Grinders, see page 17,  
FLAT2 - Narrow Belt Throughfeed machines, see page 18,

FLAT9 - Overhead Belt Grinders, see page 19.

#### MSTR2

**Mineral and Product Name:** Aluminium Oxide, CF Grade. 337DC.

**Grit range:** A300 - A3

**Backing/Weight:** X-weight.

**Contact wheel:** 50 - 70 shore, smooth.

**Applications:** Medium pressure.

**Recommended for use on the following machines:**

BG8 - Dedicated machines for Turbine Blades and Surgical Implants, see page 15,  
BG10 - Standard Backstands, see page 15,  
CENT1 - Planetary Abrasive Belt Tube Finishing machine, see page 17.

If 337DC does not break down, use 327DC instead. (low pressure). If 337DC wears too quick, use 347AC instead (high pressure). (327DC and 347AC are part of the Trizact family but not individually listed here).

#### MSTR3

**Mineral and Product Name:** Silicon carbide, with grinding aid. Designed for dry operation but can also be used wet. 3D Pyramid pattern. 407EA.

**Grit range:** A110, A90, A60, A20.

**Backing/Weight:** Flexible J-weight.

**Contact wheel:** Up to 65 shore.

**Applications:** For titanium and non ferrous metals. Recommended for belt files.

**Recommended for use on the following machines:**

BG8 - Dedicated machines for Turbine Blades and Surgical Implants, see page 15,  
CENT2 - Centreless Grinders, see page 17,  
CENT3 - Tool Post Grinders, see page 17,  
FLAT2 - Narrow Belt Throughfeed machines, see page 18,  
FLAT9 - Overhead Belt Grinders, see page 19.

#### MSTR4

**Mineral and Product Name:** Aluminium Oxide, with grinding aid, for dry operation. 3D Pyramid pattern. 237AA.

**Grit range:** A160 - A6

**Backing/Weight:** Semi flexible X-weight.

**Contact wheel:** Up to 60 to 45 shore, low pressure.

**Applications:** All operations with medium contact pressure. Long belt grinding machines, centreless machines, belt files, backstands. For hard metals, nickel, titanium, turbine blades, etc.

**Recommended for use on the following machines:**

BG8 - Dedicated machines for Turbine Blades and Surgical Implants, see page 15,  
BG10 - Standard Backstands, see page 15,  
CENT1 - Planetary Abrasive Belt Tube Finishing machine, see page 17,

#### MSTR5

**Mineral and Product Name:** Aluminium Oxide. 363FC.

**Grit range:** A300 - A30

**Backing/Weight:** YF waterproof.

**Applications:** Carbon steel, SS, nickel alloys, titanium. For centreless machines, toolpost grinders, flat throughfeed machines.

**Recommended for use on the following machines:**

BG8 - Dedicated machines for Turbine Blades and Surgical Implants, see page 15,  
CENT2 - Centreless Grinders, see page 17,  
CENT3 - Tool Post Grinders, see page 17,  
FLAT2 - Narrow Belt Throughfeed machines, see page 18,  
FLAT9 - Overhead Belt Grinders, see page 19.

#### MSTR6

**Mineral and Product Name:** Silicon Carbide. 463FC (To complement 363FC).

**Grit range:** A45, A20, A10, A6

**Backing/Weight:** YF weight.

**Applications:** Carbon steel, SS, nickel alloys, titanium. For centreless machines, toolpost grinders, flat throughfeed machines.

**Recommended for use on the following machines:**

BG8 - Dedicated machines for Turbine Blades and Surgical Implants, see page 15,

CENT2 - Centreless Grinders, see page 17,  
CENT3 - Tool Post Grinders, see page 17,  
FLAT2 - Narrow Belt Throughfeed machines, see page 18,  
FLAT9 - Overhead Belt Grinders, see page 19.

#### Cutting Speeds for Trizact:

Steel, stainless,	
non ferrous:	30 - 35 m/sec
Titanium:	12 - 15 m/sec

### CORK BELTS



Cork belts are strictly speaking not abrasive belts because they contain no abrasive minerals.

The belts are coated with shredded cork particles only.

Cork belts main application is for polishing glass but we have developed a method to use them for polishing metals, particularly on centreless tube polishing machines.

When you see your first cork belt, you will not believe that it can mirror polish. The cork particles look more like a conventional grit 24.

Cork belts need preparation and regular application of special polishing compounds to produce the almost mirror finish they are capable of. We found the following method the most effective:

Soak the cork belt in water for several hours. Fit it to the machine on which you want to use it. Use a straight piece of metal, preferably the same width as the belt, to take the tops off the cork.

The idea is to flatten the cork. Once the cork is flat, apply bar polishing compo. We recommend our grade No. 70 for a commercial mirror finish or our Grade G300 for a brighter mirror finish.

Once you start polishing the surface of the belt will slowly turn black. When the whole surface is black the belt will be in the best condition for polishing.

Keep applying compo at regular intervals.

Suitable for polishing glass, stainless steel and non ferrous metals.

## VCOR1

**Product Name:**  
Granulated cork only.

**Grit range:**  
Granulated cork only, no minerals.

**Backing/Weight:**  
Polyester cloth. X weight.

**Applications:**  
For polishing of tubes, flat bar, hollow sections, etc. Should be used with polishing compo.

**Recommended contact wheel shore hardness:**  
45 - 60 shore. See page 26.

**Recommended for use on the following machines:**  
CENT2 - Centreless Grinders, see page 17,  
CENT3 - Tool Post Grinders, see page 17.



**Gritty says . . .**

*In a finishing sequence do not jump more than 2 grit sizes.*

## CUBIC BORON NITRIDE (CBN) BELTS

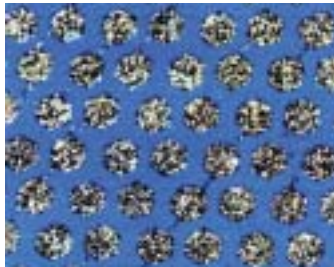

*Close up of CBN Grit*

Cubic boron nitride (CBN) is part of the Superabrasives family.

CBN's hardness is second only to diamonds. It performs particularly well on carbon and alloy steel.

Metal bonded to a tough, flexible backing. Often with a dot pattern.

Special cloth backing with an isolator and nickel layer covered with CBN.

Cutting speed: 22 - 25 m/sec.

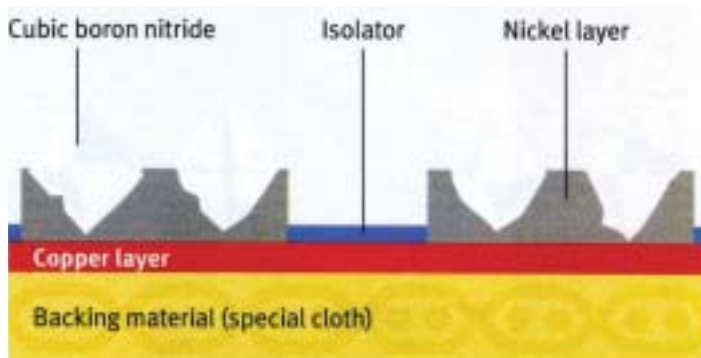

*Make up of CBN Belt*

## CBN PRODUCTS

**For grinding extremely hard and brittle materials.**

### INTRODUCTION

After diamond, CBN is the hardest abrasive mineral. CBN abrasive belts are particularly well suited for grinding hardened steel, ceramic materials, high speed steels, nickel based superalloys and chilled castings.

### VCBN1

**Code:** BA970 X

**Mineral:**  
Cubic Boron Nitride (CBN)

**Grit Sizes Equivalent to FEPA P grades:**  
251 (60-80), 126 (120), 91(180), 64 (240-320), 46 (400).

**Backing:** Aramid cloth

**Bond:** Nickel electroplated

**Pattern:** Dot

**Colour:** Blue

**Recommended Contact wheel Hardness:**  
80 -90 shore.

**Applications:**  
For hardened steel, high speed steels, thermal sprayed alloys, chilled castings. For automatic and robotic grinding machines, manual grinding machines requiring high pressure.

**Cutting Speed:** 22 - 25 m/sec

**Suitable for dry grinding.**

**Recommended for use on the following machines:**  
CENT2 - Centreless Grinders, see page 17,  
CENT3 - Tool Post Grinders, see page 17?.

## FLEXIBLE DIAMOND ABRASIVES

### INTRODUCTION

Diamond is the hardest abrasive mineral available.

It can be used for some operations where conventional abrasives are used but its main application is for grinding and finishing of materials that are too hard for conventional abrasives.

Glass and stone are two materials for which diamonds have been used for a long time.

**Other applications for diamond abrasives are:**

Grinding metal alloys with a Rockwell hardness above 55.

Tungsten Carbide

Parts coated with ceramics

Silicon carbide parts

In all these cases the diamond abrasives are used wet. Dry operations are not recommended.

### Flexible Diamond Grades

**Green**  
250 micron, 60 Mesh

**Black**  
125 micron, 120 mesh

**Red**  
74 micron, 200 mesh

**Yellow/white**  
30 micro, 360 mesh

**Yellow**  
40 micron, 400 mesh

**White**  
20 micron, 600 mesh

**Blue**  
10 micron, 1200 mesh

**Orange**  
2 micron, 8000 mesh



*A selection of Diamond Belts*

Although being by far the hardest mineral, diamond is uneconomical for machining steel, as the chemical reaction between the iron in steel and the carbon in diamonds causes fast wear.

Diamond belts are recommended for metal alloys with low carbon content and Rockwell hardness in excess of 55, flame and plasma

sprayed parts and composites, ceramics, tungsten carbide, silicon carbide and glass.

Ultra high performing but expensive diamond grain is best supported with very strong backing and robust, electroplated bonding systems.

Cubic boron nitride does not react with iron and is therefore the superior mineral for machining steel.

### Diamond minerals bonded to flexible synthetic cloth

The diamond mineral is applied either by electroplated nickel or resin construction. Nickel bonding creates a tougher and more aggressive belt. Resin bonded belts are designed for finishing and polishing.

Diamond minerals have an extremely long life and the backing for diamond belts therefore has to be designed to last as long as the mineral. Heavy duty polyester fabrics are standard.



*A typical pattern of a diamond belt*

Nickel plated Diamond Abrasives grits	Approx FEPA grit
250	60 - 80
125	120 - 180
74	180 - 240
40	360 - 400
20	600 - 800
10	1200 - 1500

### VD1

**Code:** DA930X

**Mineral:**  
Synthetic Diamond

**Grit Sizes:**  
251 (60-80), 126 (120), 91(180), 64 (240-320).

**Backing:** Special cloth with copper layer (aramid cloth).

**Bond:** Electro plated

**Pattern:** Dot

**Colour:** Green

### Applications:

Grinding of tungsten carbide sprayed rolls, other tungsten carbide parts, cermets, any other materials which cannot be ground with traditional abrasive belts.

**Recommended for use on the following machines:**

All machines for grinding hard metals which cannot be ground with traditional mineral belts.

## MICROABRASIVES

### INTRODUCTION

MICROABRASIVES were developed by the 3M Co. to produce a uniform, repeatable and predictable surface finish from approx. 60 CLA to approx. 0.5 CLA.

The finest finishes standard FEPA graded abrasive belts can produce are approx. 5 CLA.

The finest finishes Engineered abrasive belts can produce are approx. 0.01 CLA.

Abrasive belts cannot be consistent. They produce a coarse finish when new. They then settle down to a medium finish over a long period until they are worn when they stop cutting and produce a finer finish.

This is why the Microfinishing system does not work with belts but with rolls.

The roll of Microfinishing Abrasive is constantly fed at a pre-set rate so that fresh abrasive minerals produce an even finish throughout the life of then roll.

The system is very similar to the way traditional typewriter ribbons used to work

Fresh abrasive is incrementally indexed resulting in uniform stock removal and finish.

**Imperial Microfinishing Film**  
Consists of precision micron graded minerals bonded to a polyester film backing.

**Imperial Lapping Film**  
Consists of super fine graded precision minerals bonded to a polyester film backing. Available with aluminium oxide and silicon carbide

**Imperial Diamond Lapping Film**

Consists of micron graded diamond particles bonded to a polyester film backing.

Available with diamond.

Finishing with Microabrasives can be called MICROFINISHING or SUPERFINISHING

Microabrasives produce uniform repeatable and Predictable finishes.

The Microabrasive Finishing System has very little in common with abrasive belts.

1. It has a polyester film backing which is far more precise than the cloth backing of abrasive belts
2. The abrasive mineral is graded much finer
3. Microfilm is used on a roll, not a belt.

#### Surface Roughness Table

This table is a rough guide only. The lower figure represents the finish on aluminium and the higher figure the finish on chilled iron.

Microfilm grit size equivalent for electro coated film	Surface finish in Ra metric	Approx. FEPA
60 micron	0.8 - 0.2	220
30 micron	0.4 - 0.15	400
15 micron	0.22 - 0.06	1200
9 micron	0.12 - 0.035	1800
3 micron	0.03 - 0.015	8000
12 micron	0.07 - 0.02	
9 micron	0.03 - 0.015	
5 micron	0.01 - finer than 0.01	

#### Microfilm Roll Sizes

- 50mm x 3" core
- 100mm x 3" core
- 200mm x 3" core

Microfilms can be wound with grit on the outside or with grit on the inside, depending on the Microfinisher used.



Microabrasive film rolls.

### APPLICATIONS FOR MICROFINISHING ABRASIVE ROLLS

- Textile rolls
- Rotogravure
- Anilox rolls
- Paper making rolls
- Yankee rolls
- Rubber rolls
- Gudgeon pins
- Bearing surfaces
- Shafts
- Shock absorber pistons

### RECOMMENDED MACHINES FOR MICROFINISHING ABRASIVE ROLLS

Microfinishing heads for mounting on lathes or roll grinders.

Available in 50mm, 100mm and 200mm working width.

#### Surface measurement terms and graphs

These are the main terms used in our industry:

Ra - m (CLA) metric (in micro mm).

Arithmetical average value of all absolute distances of the roughness profile R from the centre line within the measuring length.

Ra - " (CLA) imperial  
Same as Ra metric but in micro inches.

There are many more surface roughness measurement systems. Please consult technical descriptions on Google.

#### Some comparisons

Ra-m	Ra-"
0.03	1.2
0.06	2.5
0.09	3.7
0.13	5.0
0.16	6.7
0.19	7.5
0.38	15.8
0.73	30.1
1.59	62.7
3.18	125.5



Microfinishing principle

1. New film roll
2. Contact Pad
3. Spent film

## MICROFINISHING FILM

There are several grades of Microfinishing films. We have listed below the two most popular grades.

### MF1

**Mineral and Product Name:**  
Aluminium Oxide.  
3M 262L.

**Grit range:** 80 - 9 micron

**Backing/Weight:**  
3 mil polyester film.

**Applications:**  
Cylindrical parts of steel, stainless, aluminium, etc.

### MF2

**Mineral and Product Name:**  
Aluminium Oxide.  
3M 272L.

**Grit range:** 80 - 9 micron

**Backing/Weight:**  
5 mil polyester film.

**Applications:**  
Cylindrical parts of steel, stainless, aluminium, etc.

### MF3

**Mineral and Product Name:**  
Diamond.  
675L.

**Grit range:** 20, 30, 45, 74, 125 micron

**Backing/Weight:**  
5 mil polyester film.

**Applications:**  
Microfinishing hard metals, tungsten carbide, ceramics, chilled iron, etc.

**Recommended for use on the following machines:**

- MIC1 - Microfinisher 50mm, See page 16,
- MIC2 - Microfinisher 100mm, See page 16.

## MICROFINISHING



Microfinishing unit mounted on the tool post of a lathe.

Microfinishing abrasives produce the most uniform, repeatable and predictable finishes of all coated abrasives.

They are not used as belts but as rolls which work similar to the ribbon on old typewriters.

Finishes finer than 1CLA are possible.

Must be used with a dedicated microfinishing machine which is

mounted on the toolpost of a lathe or mounted on a roll guide.

For more information ask for our microfinishing catalogue.

**UNIFORM  
REPEATABLE  
PREDICTABLE  
FINISHES  
FROM 60 CLA  
TO 0.5 CLA**

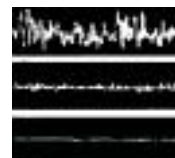



## ABRASIVE IMPREGNATED NON-WOVEN NYLON BELTS

### INTRODUCTION

Abrasive impregnated non woven nylon material was invented and developed by the 3M Company under the registered brand name of SCOTCHBRITE.

SCOTCHBRITE has for many people become a generic name for abrasive impregnated non woven nylon although it remains a registered brand name of 3M and only material made by 3M can be called SCOTCHBRITE.

Because there are now several manufacturers of abrasive impregnated non woven nylon it is important that you are aware of this distinction.

Prices, quality and finishes vary between the different manufacturers

SCOTCHBRITE as made by the 3M Company is still the benchmark and the finish you can achieve with it is the most consistent and efficient.



Abrasive impregnated nylon belts are available in coarse, medium and fine and are used for blending after abrasive belts or for satin finishing.

Nylon belts are used for blending after grinding with abrasive belts, for satin finishing for light deburring, for cleaning and for conditioning.

The three most popular nylon belt grades are:

**Coarse A/O - brown**  
Approx. FEPA grit 120-150.

**Medium A/O - Maroon**  
Approx. FEPA grit 220-240.

**Fine A/O - Blue**  
Approx. FEPA grit 320-360.

**Superfine SiC - Black**  
Approx. FEPA grit 600

Recommended cutting speeds for Nylon Belts:

**Cleaning**  
11 - 30 m/sec.

**Deburring**  
28-36 m/sec.

**Finishing**  
5 - 15 m/sec.

**Oxide removal**  
18 - 32 m/sec.

Abrasive impregnated non woven nylon is used for light deburring, cleaning, blending, satin finishing of most metals, plastics and composites.

For belts the non woven web is interlined with cloth. They can be used wet or dry.

### MYNL1

**Mineral and Product Name:**  
Aluminium Oxide.  
Scotchbrite.

**Grit range:** Coarse (beige), maroon (medium), blue (fine).

**Backing/Weight:**  
Scrim back or low stretch.

**Applications:**  
Light deburring, satin finishing.

### MYNL2

**Mineral and Product Name:**  
Silicon Carbide.  
Scotchbrite.

**Grit range:** Super fine (black).

**Backing/Weight:**  
Scrim back or low stretch.

**Applications:**  
Very fine satin finishing of stainless steel.

**Recommended contact wheel:**  
All grades.

**MYNL1 and MYNL2 both recommended for use on the following machines:**

PORT2 - Abrasive Belt Files, see page 11,  
PORT3 - Abrasive Belt Grinders, see page 15,  
PORT4 - Bent Tube Polisher, see page 17,

PORT5 - Portable Abrasive Belt Edge Blending and Grinding machine, see page 12,  
PORT6 - Roto-Sat, see page 13,  
PORT7 - For Expanding Wheels, see page 13,

CENT2 - Centreless Grinders, see page 17,  
CENT3 - Tool Post Grinder, see page 17.

Nylon	Micro inch	FEPA
Coarse A/O	62-72	80-120
Medium A/O	32-40	150-180
Very Fine A/O	6-12	220-320
Super Fine SiC	4-6	360-800

**Recommended Speeds:**

**For decorative finishing:**  
500 - 3000 sfpm

**For deburring and removal of surface imperfections:**  
4000 - 6000 sfpm

**For cleaning and conditioning:**  
2000 - 4000 sfpm

**Microinch finishes produced by aluminium oxide nylon belts:**

On Aluminium	On Stainless Steel
Coarse 130 - 150	60 - 70
Medium 80 - 100	30 - 40
Fine 15 - 35	5 - 12

**Microinch finish produced by Silicon Carbide nylon belts:**

On Aluminium	On Stainless Steel
Super Fine 8 - 12	4 - 6

### VNVL1

**Mineral and Product Name:**  
Aluminium Oxide and Silicon Carbide. KV 707 T (X-flex) KV707 X (low stretch).

**Grit range:**  
Coarse - brown.  
Grit 100. Aluminium Oxide.  
Medium - red.  
Grit 180. Aluminium Oxide.  
Fine - blue.  
Grit 240. Aluminium Oxide.  
Very Fine - grey.  
Grit 400. Silicon Carbide.

**Backing/Weight:**  
Non woven nylon with polyester cloth.

**Applications:**  
Cleaning, satin finishing, conditioning and light deburring of all materials.

**Recommended contact wheel shore hardness:**  
45 - 60. See page 26.

**Recommended for use on the following machines:**  
PORT2 - Abrasive Belt Files, see page 11,  
PORT3 - Abrasive Belt Grinders See page 11,  
PORT4 - Bent Tube Linisher, see page 12,

PORT5 - Portable Abrasive Belt Edge Blending and Graining machine, see page 12,  
PORT6 - Roto-Sat, See page 12,  
PORT7 - Abrasive Cloth Belts for Expanding Wheels, see page 12,

CENT1 Planetary Abrasive Belt Tube Finishing machines, see page 17,  
CENT2 - Centreless Grinders, see page 17,  
CENT3 - Tool Post Grinders, see page 17.

## POLISHING BELTS INTRODUCTION

Abrasive belts are not capable of producing a mirror polish. The traditional method is to use cotton polishing mops, but if you have a machine that cannot use mops you will have to use cotton or felt polishing belts which have to be regularly coated with a special polishing compound.

There are polishing belts for every machine, from portable to automatic multi heads.

## SURTX POLISHING BELTS



SURTX polishing belts are available as 100 % synthetic or 100 % woolen.

Either belt can produce a finish approaching a No. 8 mirror.

The belts perform best at 18 m/sec.

SURTX polishing belts have to be conditioned before they can develop their full potential.

This means building up a coating of polishing compo and letting the belt get warm.

It is the polishing compo that determines the finish. The SURTX polishing belt simply acts as a carrier for the compo.

### APPLICATIONS FOR POLISHING BELTS

Mirror polishing of tubes, round bar and rolls on semi automatic and fully automated machines.

Mirror polishing of stainless steel sheet and fabrications

### RECOMMENDED MACHINES

CENT2 - Centreless Grinders, see page 17,  
CENT3 - Tool Post Grinders, see page 17.  
PORT9 - Roto-Sat, see page 13.

As a SURTECH customer you get free advice and free test facilities.

## FELT POLISHING BELTS



Felt polishing belts are the traditional way of polishing metals and lacquer on machines which cannot use mops or buffs. They used to be particularly popular on pad sanders for polishing lacquer coated furniture.

Felt polishing belts consist of a layer of approx. 4mm wool felt interlined with a single or double layer of canvas.

The canvas prevents the felt belt from stretching.

The wool felt is available in several densities.

We have tested several densities and found 0.44 the best for general polishing.

Felt belts are thicker and tougher than SURTX polishing belts but not suitable for all machine models.

### APPLICATIONS FOR FELT POLISHING BELTS

Mirror polishing of tubes, round bar and rolls on semi automatic and fully automatic machines.

### RECOMMENDED MACHINES

CENT2 - Centreless Tube Polishing machines Models 504 BC, 128, *see page 17*, FLAT9 - Pad Sanders Models L84, L85 and LS90, *see page 19*.

As a SURTECH customer you get free advice and free test facilities.

## SPECIALITY ABRASIVE BELTS

Demands for the quality of sheet edge deburring have changed. It is no longer accepted to simply remove upstanding burrs and to leave edges sharp. Customers now want all edges deburred and rounded for technical and for safety reasons.

Traditional abrasive belts struggle to fulfill these new standards and it was therefore necessary to develop new belts.

Messrs Lissmac have been very successful with their grind, deburring and de-scaling belts.

Traditional belts run along the length of sheet metal components, the Lissmac belts run across the width.

The unique abrasive flap belt consists of individual section mounted on an endless thick rubber belt.



Diagram of deburring head with top and bottom abrasive flap belt



Part of an abrasive flap belt



The individual abrasive flap sections

### L1

**Mineral and Product Name:** Aluminium Oxide cloth flaps alternating with nylon flaps. SBM-B-AO.

**Grit range:** 40, 60, 80, 120

**Backing:** Thick rubber belt.

**Sizes:** For 1000mm or 1500mm wide machine.

**No. of segments:** 1000mm = 43  
1500mm = 57.

**Applications:** Deburring and rounding of sheet metal edges

**Recommended for use on the following machines:** SBM-S, *see page 19*.

### L2

**Mineral and Product Name:** Silicon Carbide cloth flaps alternating with nylon flaps. SBM-S-SIC.

**Grit range:** 40, 60, 80, 120

**Backing:** Thick rubber belt.

**Sizes:** For 1000mm or 1500mm wide machine.

**No. of segments:** 1000mm = 43  
1500mm = 57.

**Applications:** Deburring and rounding of sheet metal edges

**Recommended for use on the following machines:** SBM-S, *see page 19*.



The wire brush endless belt as mounted on the machine

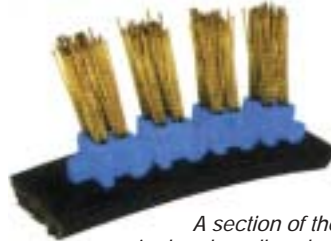

A section of the wire brush endless belt

### L3

**Mineral and Product Name:** These belts do not use abrasive minerals but wire. SBM-B-W.

**Grit range:** n/a

**Backing:** Thick rubber belt

**Sizes:** For 1000mm or 1500mm wide machine.

**No. of segments:** 1000mm = 43  
1500mm = 57.

**Applications:** Cleaning and removing oxide scale from edges of steel sheets.

**Recommended for use on the following machine:** SBM-B, *see page 19*.



The Lissmac abrasive belt with a thick rubber backing to improve deburring action

### L4

**Mineral and Product Name:** Aluminium Oxide belt. SBM-GS-AO.

**Backing:** Thick rubber belt

**Grit range:** 40, 60, 80, 120

**Size:** 1000mm machine:  
4000mm x 70mm  
1500mm machine:  
5000mm x 70mm

**Recommended for use on the following machines:** FLAT5 - Lissmac Abrasive Belt Slag Grinder, SBM-GS, *See page 18*, FLAT8 - Lissmac Deburring and Edge Rounding machine, SBM-L, *See page 19*.

### L5

**Mineral and Product Name:** Zirconia belt. SBM-GS-Z.

**Grit range:** 40, 60, 80, 120

**Backing:** Thick rubber belt.

**Size:** 1000mm machine:  
4000 x 70mm  
1500mm machine: 5000 x 70mm

**Recommended for use on the following machines:** FLAT5 - Lissmac Abrasive Belt Slag Grinder, SBM-GS, *See page 18?*, FLAT8 - Lissmac Deburring and Edge Rounding machine, SBM-L, *See page 19*.



Lissmac sheet edge deburring and corner rounding machines are available with a set of top and bottom belts or with two sets of top and bottom belts.

# The Machines

## Abrasive Belts by Machine Models

### SURTECH RECOMMENDED 'BENCHMARK' ABRASIVE BELTS

If you count all available variations, excluding grit sizes, most manufacturers can offer you around 50 different abrasive belt types and grades. Between several manufacturers you will be able to choose a belt for every grinding, deburring and finishing operation.

Such a vast choice is at the same time excellent and confusing. Excellent, because you can be confident that somewhere there is the belt for you. Confusing, because it may need a lot of tests and take a long time to find it.

SURTECH know all the belts from all major manufacturers. As machine suppliers we can judge better than anyone else which belts perform best on a given machine for a given operation. Machines have different, cutting speeds, different contact wheels and different contact pressure requirements - all features which influence belt performance.

SURTECH have therefore concentrated on recommending 'Benchmark' belts on the types and models of machines sold by SURTECH.

Use our 'Benchmark' recommendations to get going. Once you have developed your operational sequences test other belts against our recommended belts and if you find any that perform better change over to them.



### Gritty says . . .

*Belts for belt files are the smallest abrasive belts available. A top quality specification is essential to guarantee long life and perfect belt tracking.*

*The abrasive belt joint needs to be tough and flexible to stand up to their small drive and contact wheels of the belt files.*

## PORTABLE ABRASIVE POWER TOOLS

### PORT1 SURTX ORIGINAL BELT FILE



The SURTX belt file is the oldest and still the best portable abrasive belt air driven power tool on the market.

Its triplanetary drive allows the use of abrasive belts 3mm, 6mm and 13mm wide and 610mm long without coming off. A range of about 25 quick change contact arms will cover most operations from grinding and finishing of fillet welds to grinding openings as small as 13mm x 13mm and deburring sheet edges.

The SURTX belt file can be used with abrasive belts for grinding, nylon belts for finishing and cotton belts for polishing.

**Air motor:** 0.5 HP  
**Motor rpm:** 20,000  
**Abrasive belt sizes:** 610mm long x 3mm, 6mm, 13mm wide  
**Weight:** 1.4 kg

**Recommended Abrasive Belts:**

VA1, see page 3, VCER1, see page 5, VCA1, see page 5, VNYL1, see page 9.

## PORT2

### SURTX PNEUMATIC BELT FILE AND BELTER

Pneumatic abrasive belt files are simpler versions of the SURTX ORIGINAL BELT FILE. They have only a drive wheel and a contact wheel instead of the triplanetary wheel system.

For most operations they are perfectly adequate and some of them even share the same contact arms.

SURTX PNEUMATIC BELT FILES are also available with stronger motors and with longer and wider belts.



### SURTX AIR ROTO-FILE 610

**Air motor:** 0.37 HP  
**Motor rpm:** 20,000  
**Abrasive belt sizes:** 6mm, 10mm, 13mm wide x 305mm long  
**Weight:** 1 kg

**Recommended Abrasive Belts:**

VNYL1, see page 9, VZ2, see page 4, VCER1, see pages 4 and 5, VCER2, see page 5.

### SURTX AIR ROTO-FILE 620

**Air motor:** 0.45 HP  
**Motor rpm:** 20,000  
**Abrasive belt sizes:** 6mm, 10mm, 13mm, 20mm, 25mm wide x 305mm long  
**Weight:** 1.3 kg

**Recommended Abrasive Belts:**

VNYL1, see page 9, VZ2, see page 4, VCER1, see pages 4 and 5, VCER2, see page 5.

## PORT3 SURTX ELECTRIC ROTO-FILE 710

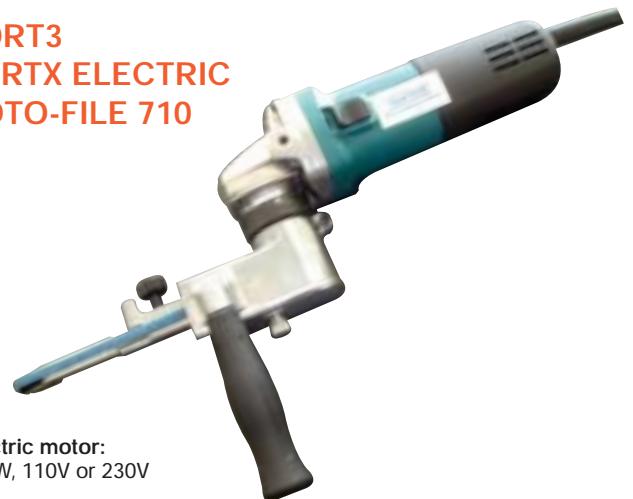

**Electric motor:** 710W, 110V or 230V

**Motor rpm:** 11,000

**Abrasive belt sizes:** 3mm, 6mm, 12mm wide x 457mm long (610mm with extension arm).

**Weight:**

**Recommended Abrasive Belts:**

VNYL1, see page 9, VCA1, see page 5, VCER1, see pages 4 and 5.

## PORT4 ROTO-BELTER FLEX PORTABLE ABRASIVE BELT GRINDER

Portable abrasive belt grinders are more powerful and larger belt files. The rules for abrasive belt files also apply to abrasive belt grinders.

**Electric motor:**  
1.2 kW, 110V or 230V

**Variable Speed:** 10 - 30 m/sec

**Abrasive belt size:**  
40mm x 620mm

**Weight:** 4 kg

**Recommended Abrasive Belts:**

VZ2, see page 4, VCER2, see page 5, VCA1, see page 5, VZ1, see page 4, VCER1, see pages 4 and 5, VNYL1, see page 9.



## PORT5 ROTO-BELTER-WS3800 PORTABLE ABRASIVE BELT GRINDER

**Electric motor:**  
1 kW, 110V or 230V

**Variable Speed:**  
2700 - 11000 m/sec

**Abrasive belt size:**  
25mm x 760mm

**Weight:**

**Recommended**

**Abrasive Belts:**

VZ2, see page 4, VCER2, see page 5, VCA1, see page 5, VZ1, see page 4, VCER1, see pages 4 and 5, VNYL1, see page 9.



## PORT6 ROTO-BELTER-WSV4100 PORTABLE ABRASIVE BELT GRINDER

**Electric motor:**  
2 kW, 110V or 240V

**Speed:**  
8500 rpm

**Abrasive belt size:**  
40mm x 1000mm

**Weight:**

**Recommended Abrasive Belts:**

VZ2, see page 4, VCER2, see page 5, VCA1, see page 5, VZ1, see page 4, VCER1, see pages 4 and 5, VNYL1, see page 9.



## PORT7 PORTABLE TUBE FINISHING MACHINES

### Model ROTO-TUBE GRI

**Electric motor:**  
Flex, 110V or 230V, 1.2 kW

**Variable Speed:**  
1200 - 3700 rpm

**Abrasive belt size:**  
12mm, 15mm, 35mm x 650mm

**Weight:** Approx. 3.5 kg.

**Recommended**

**Abrasive Belts:**

VZ2, see page 4, VCER2, see page 5, VCA1, see page 5, VZ1, see page 4, VCER1, see pages 4 and 5, VNYL1, see page 9.



### Model ROTO-TUBE POL

**Electric motor:**  
Flex, 110V or 230V, 1.2 kW

**Variable Speed:**  
1200 - 3700 rpm

**Abrasive belt size:**  
10mm, 20mm, 40mm x 820mm

**Weight:** Approx. 3.7 kg.

**Recommended**

**Abrasive Belts:**

VZ2, see page 4, VCER2, see page 5, VCA1, see page 5, VZ1, see page 4, VCER1, see pages 4 and 5, VNYL1, see page 9.



## PORT8 PORTABLE ABRASIVE BELT EDGE BLENDING AND GRAINING MACHINE



**Abrasive belt sizes for portable abrasive belt edge graining machines**

Roto-Liner 280mm x 60mm

**Recommended abrasive belts:**

VA1, see page 3, VZ1, see page 4, VNYL1, see page 9.



**Gritty says . . .**

To avoid having to change belts too often, use only top quality, long life grades as recommended above.

## PORT9 ROTO-SAT



Pneumatic wheel 120mm dia x 80mm wide for abrasive belts 90mm wide x 395mm long.

or

Pneumatic wheel 92mm dia x 96mm wide x 19mm bore for abrasive belts 100mm wide x 295mm long.

Either with 19mm keyway bore or with M14 thread.

The above portable abrasive power grinders can all be used with pneumatic wheels or expanding rubber wheels as shown below.

## PORT10 ABRASIVE CLOTH BELTS FOR PNEUMATIC WHEELS

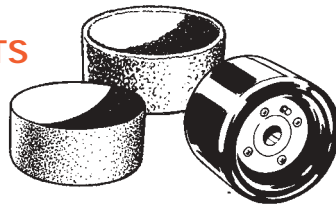

The advantage of pneumatic wheels is that they can be pumped up to any hardness from very soft to very hard.

Pneumatic wheels are used mainly for finishing and it is important that the belts used on them produce a consistent finish over a long time.

Our recommendation is to use standard aluminium oxide belts for general purpose applications, Zirconia for grinding stainless steel. Compact grain for a perfect decorative finish and nylon belts for a satin finish. Engineered belts for polishing.

### Abrasive belt sizes for pneumatic wheel

92mm x 96mm	100mm x 296mm
120mm x 80mm	395mm x 90mm
75mm x 75mm	
120mm x 35mm	

### Recommended belts for grinding with pneumatic wheel machines:

VZ2, see page 4, VCER2, see page 5, VCA1, see page 5, VZ1, see page 4, VCER1, see pages 4 and 5, VNYL1, see page 9.

## PORT11 ABRASIVE CLOTH BELTS FOR EXPANDING WHEELS

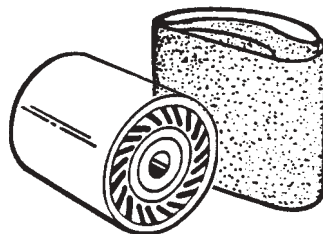

Expanding wheels are available in one hardness only. They are more aggressive than pneumatic wheels and can be used for both grinding and graining.

Expanding wheels are not recommended for abrasive impregnated non woven nylon web belts. They perform better on pneumatic wheels.

Expanding wheel size: 100mm dia x 100mm wide x 19mm bore with keyway.

To fit abrasive belts 316mm long x 100mm wide.

### Recommended belts for grinding with expanding wheel machines:

VZ2, see page 4, VCER2, see page 5, VCA1, see page 5, VZ1, see page 4, VCER1, see pages 4 and 5, VNYL1, see page 9.

## PORT12 ABRASIVE BELT HEAD FOR FLEXIBLE SHAFT MACHINES

### Abrasive belt sizes for flexible shaft machines

GSB 50/10 450mm x 50mm

### Recommended belts for grinding with flexible shaft machines

VZ2, see page 4, VCER2, see page 5, VCA1, see page 5, VZ1, see page 4.



## BG1 BENCH GRINDERS, POLISHERS

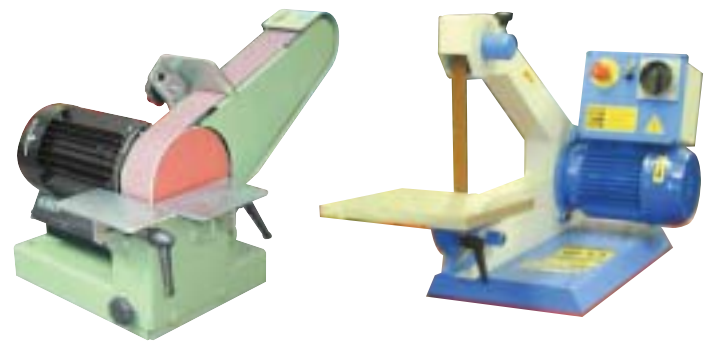

Model	Belt Size
10-50/1	1000mm x 50mm
L50	1360mm x 25mm
L52	2000mm x 50mm
413 MINI	2000mm x 50mm
Vanco	1100mm x 6 - 50mm

Recommended belts for grinding with bench grinders: VA4, see page 3, VZ1, see page 4.

## BG2 ABRASIVE BELT SHEET EDGE DEBURRING MACHINES

### Abrasive belt sizes for bench grinders

Model 420	2000mm x 25mm, 50mm
Model 410	1500mm x 12mm - 50mm

Recommended belts for grinding and deburring: VZ1, see page 4.



## BG3 4 WHEEL MACHINES

Abrasive belt sizes for 4 wheel machines

Model 213  
2000mm x 13mm, 100mm

Recommended belts for grinding and deburring:  
VA4, see page 3, VZ1, see page 4,  
VA2, see page 3.



## BG4 VERTICAL ABRASIVE BELT GRINDERS

Abrasive belt sizes for vertical abrasive belt grinders

Model 623  
2000mm x 6mm - 75mm

Recommended belts for grinding and deburring:  
VA4, see page 3, VZ1, see page 4.



### Gritty says . . .

*Belts on contact wheels remove metal faster and last longer than belts used on contact platens.*

## BG5 LINISHERS

Linishers are abrasive belt machines with a flatbed platen that is used for grinding flat surfaces and for general deburring.



### Abrasive belt sizes for linishers

L61 AMP	1000mm x 100mm
L83 AMP	1750mm x 150mm
310 FIN	1000mm x 100mm
311 FIN	1500mm x 150mm
332 FIN	2000mm x 200mm
333 FIN	2000mm x 200mm
334 FIN	2000mm x 200mm
303 MAR	1750mm x 150mm
304/306 MAR	2000mm x 250mm

Recommended belts for grinding with linishers:  
VZ1, see page 4, VZ2, see page 4.

## BG6 MANUAL EDGE AND CORNER GRINDING MACHINES



Abrasive belt sizes for edge and corner grinders

Model	Belt Size
127	2000mm x 75mm

Recommended belts for grinding with edge and corner grinders:  
VZ1, see page 4, VZ2, see page 4.

## BG7 AUTOMATIC WELDED CORNER GRINDERS

Abrasive belt sizes for automatic corner grinders

Model	Belt Size
130	2000mm x 75mm
132	2000mm x 150mm

Recommended belts for grinding and blending with automatic corner grinders:  
VZ1, see page 4.



### Gritty says . . .

*Most machines can be used with different contact pressures. Low contact pressure operations require different belt grades than high contact pressure operations.*

## BG8 DEDICATED MACHINES FOR TURBINE BLADES AND SURGICAL IMPLANTS



Abrasive belt sizes for turbine blade finishing machines

Model	Belt Size
411	1120mm x 6mm - 50mm
704	2500mm x 12mm - 75mm
491	2500mm x 12mm - 75mm

Recommended belts for polishing with dedicated turbine blade machines:

VCER1, see pages 4 and 5, VCA1, see page 5, MSTR1, see page 6, MSTR2, see page 6, MSTR4, see page 6, VA1, see page 3, VA2, see page 3, VA3, see page 3, VA4, see page 3.



## BG9 BELT GRINDERS

Abrasive belt sizes for belt grinders:

Model	Belt Size
ABG 75	2000mm x 75mm
ABG 150	2000mm x 150mm
EG120 FIN	1500mm x 120mm
EG75 FIN	2000mm x 75mm
EG150 FIN	2000mm x 150mm
ANM	2500mm x 75mm
ANM	2500mm x 150mm
531 FIN	2500mm x 100mm
532 FIN	2500mm x 200mm

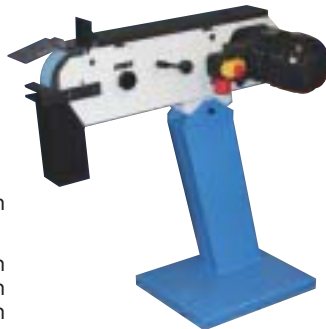

Recommended abrasive belts for grinding and deburring: VA4, see page 3, VZ1, see page 4, VCER2, see page 5.

## BG10 BACKSTANDS

General purpose belt for heavy duty grinding of all metals with high stock removal rates.

Used on manual machines, centreless machines and throughfeed machines.

Mounted on serrated contact wheels from 65 to 80 shore hardness.

These power ratios are possible on some manual machines and on a number of semi automatic dedicated grinding machines.

Abrasive belt sizes for backstands

Marpol 504	2500mm x 50mm
Marpol 554	2500mm x 50mm
Metabo	3500mm x 100mm



## BG11 EXTRA HEAVY DUTY MANUAL ABRASIVE BELT GRINDERS



For removing feeders and gates from castings. For removing flash and parting lines from forgings.

Abrasive belt length usually 3500mm

Model	Belt Size
REMA SMG	3500mm x 100mm

Recommended abrasive belts for BG10 and BG11:

VZ1, see page 4, VZ2, see page 4, VA1, see page 3, VA2, see page 3, VA3, see page 3, VA4, see page 3, VS1, see page 3, MSTR1, see page 6, MSTR2, see page 6, VZ3, see page 4, VCER1, see pages 4 and 5.

### FOR GRINDING OF STAINLESS STEEL

### FOR GRINDING OF TITANIUM

Titanium alloys are difficult to grind. The high strength of titanium alloys is a major cause of poor grindability. Added to this is the chemical adhesion of titanium to the abrasive grain.

Greatly improved performance can be achieved by the use of specially designed grinding fluids.

Highest improvement is achieved with lubricants containing tri-potassium phosphate. Specially formulated for use as coolant/ lubricant for abrasive belt grinding of titanium.



You can sit down or stand up

Abrasive belt sizes for extra heavy duty manual abrasive belt grinders

REMA	3500mm x 100mm
------	----------------

Recommended belts for grinding with extra heavy duty manual abrasive belt grinders

VZ3, see page 4, VCER1, see pages 4 and 5.

## BG12 NOTCHERS

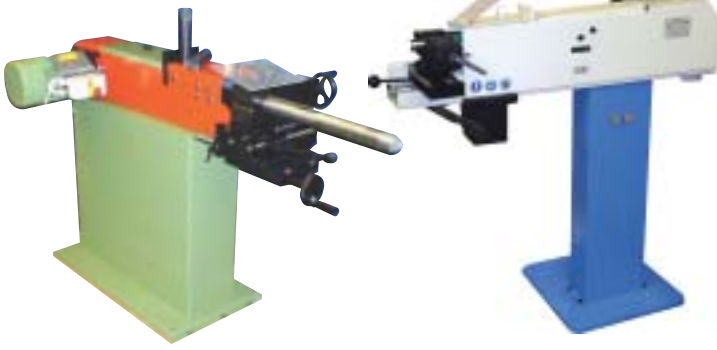

### Abrasive belt sizes for notchers

TN 75	2000mm x 75 mm
TN201 SPA	2000mm x 75mm
TN220 SPA	2000mm x 120mm

Recommended belts for grinding with tube notchers  
VZ1, see page 4, VZ2, see page 4.

## MIC1 MICROFINISHER

50mm wide



Max. working width: 50mm

Air supply: 7bar

Pneumatic cylinder stroke: 30mm

Contact pressure: 0 - 280 N

Oscillation stroke: 2mm or up to 5mm

Microfilm feed speed: 0-120mm/min

Weight: Approx. 12 kg

## MIC2 MICROFINISHER

100mm wide

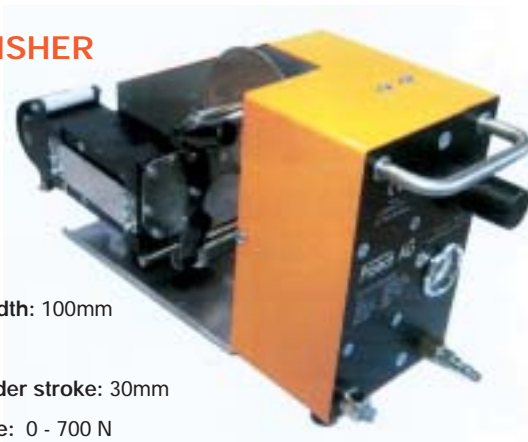

Max. working width: 100mm

Air supply: 7bar

Pneumatic cylinder stroke: 30mm

Contact pressure: 0 - 700 N

Oscillation stroke: 4mm, 6mm or 2mm

Microfilm feed speed: 0-150mm/min

Weight: Approx. 38 kg

## CENT1 PLANETARY ABRASIVE BELT TUBE FINISHING MACHINES

### Abrasive belt sizes for planetary tube finishing machines

Model Toy PBZ	940mm x 60mm
Model Fintec 142	950mm x 50mm
Model Rema TPS	740mm x 30mm

Recommended belts for grinding  
with planetary tube finishing machines  
VCA1, see page 5, VZ2, see page 4,  
VS1, see page 3, VSC1, see pages 3 and 4,  
VNYL1, see page 9, MSTR1, see page 6,  
MSTR2, see page 6.



## CENT2 CENTRELESS GRINDERS

Centreless grinders can be used for heavy duty grinding,  
finishing and polishing of tubes and round bars.



A six head fully  
automated tube grinder.





Multihead centreless tube finishing machines with automatic loading and unloading.

**Abrasive belt sizes for centreless machines**

Model 128	2000mm x 75mm
Model 504 BC	2500mm x 75mm
Model	3000mm x 150mm

Model SurfENG ST 2500 mm x 150mm  
 Model SurfENG STO 4000mm x 150mm  
 (Both Models ST and STO are available with optional belt lengths.  
 Check with your manual)

**Recommended abrasive belts for grinding with centreless machines**  
 VZ2, see page 4, VCA1, see page 5, VS1, see page 3, VSC1, see pages 3 and 4, MSTR4, see page 6, MSTR5, see page 6, MSTR6, see page 6.

**CENT3  
 TOOL POST GRINDERS**

Tool post grinders are used for heavy duty grinding, for finishing and for polishing of rolls, tubes and pipes.

**Abrasive belt sizes for tool post grinders**

LEH III	2000mm x 50mm
LEH V	3000mm x 75mm
LEH VII	3500mm x 100mm

**Recommended belts for polishing with tool post grinders**  
 VZ2, see page 4, VCA1, see page 5, VS1, see page 3, VSC1, see pages 3 and 4, MSTR4, see page 6, MSTR5, see page 6, MSTR6, see page 6.



**BG14  
 FLOOR AND SWING GRINDERS**

**Abrasive belt sizes for floor and swing grinders**

126 swing	2000mm x 75mm
125 floor	2000mm x 75mm

**Recommended belts for grinding with floor and swing grinders**  
 VZ1, see page 4, VZ3, see page 4.



125 Floor Grinder

126 Swing Grinder

**PG1  
 POWER GRINDERS**



A Horizontal Power Grinder

**Abrasive belt sizes for power grinders**

REMA	3500mm x 150mm
------	----------------

**Recommended belts for grinding with power grinders**

Dedicated belt for extra heavy duty grinding of hard and heat sensitive metals on Power Grinders or other machines with very high contact pressures.

Mounted on serrated contact wheels with polyurethane tyre from 80 to 95 shore hardness or even solid steel contact wheels. Contact wheels up to 600mm diameter.

A grinding aid in the bond reduces heat, thus helping to prevent damage to the part and prolonging belt life.

If these belts are used for manual grinding without sufficient contact pressure they will glaze well before the end of their designed life.

Power grinding starts with 5 HP per 25mm belt width and can be as high as 15 HP per 25mm belt width.

Use belts with ceramic aluminium oxide minerals which stay sharp and fracture at a controlled rate exposing new cutting edges as they wear.

**Recommended abrasive belts for power grinding:**  
 VCER1, see pages 4 and 5, VCER2, see page 5.



A Vertical Power Grinder removing feeders from castings

**FLAT1  
 THROUGHFEED  
 EDGE DEBURRER**

**Abrasive belt sizes for throughfeed edge deburrer**

FIN 8 series models	900mm x 35mm
---------------------	--------------

**Recommended abrasive belts for throughfeed edge deburrer:**  
 VZ1, see page 4, VZ2, see page 4.



**Gritty says . . .**

Only the correct combination of belts and contact wheels will result in maximum performance and economical operation.

## FLAT2 NARROW BELT THROUGHFEED MACHINES

The principal of these machines is the same as that of wide belt machines but with a narrower width capacity

We consider machines with a width capacity of 600mm and wider as wide belt machines and machines below 600mm as throughfeed machines.



### Abrasive belt sizes for throughfeed machines

Model STN	1800mm x 300mm
Model SG 150	2000mm x 150mm
Model SG 300	2000mm x 300mm
FST	2500mm x 150mm
G3 GEC	1900mm x 320mm
C150 VG	1900mm x 150mm
T300 VG	1900mm x 300mm

### Recommended belts for grinding with throughfeed machines:

VZ2, see page 4,  
VCER1, see pages 4 and 5,  
VCA2, see page 5, VS1, see page 3,  
VNYL1, see page 9, MSTR4, see page 6,  
MSTR5, see page 6, MSTR6, see page 6.



## FLAT3 WIDE BELT THROUGHFEED MACHINES

This is the most widely used wide belt machine, used for deburring, graining and general finishing.

### Abrasive belt sizes for general purpose wide belt machines

M6 GEC	1525mm x 635mm
M9 GEC	1525mm x 940mm
G6 GEC	1900mm x 670mm
T650 VG	1900mm x 650mm
G11 GEC	2200mm x 1120mm
G13 GEC	2200mm x 1320mm
G16 GEC	2200mm x 1670mm

### Recommended belts for finishing with general purpose wide belt machines:

VZ2, see page 4, VCA1, see page 5, VS1, see page 3.



## FLAT5 LISSMAC ABRASIVE BELT SLAG GRINDER SBM-GS

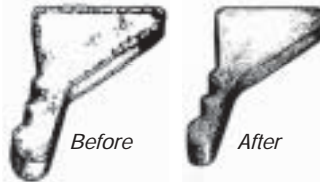

### Abrasive belt sizes for Lissmac Slag Grinder:

#### 1000mm wide model

Abrasive belt: 4000 x 75mm  
Combi flap belt: 45 Inserts

#### 1500mm wide model

Combi flap belt: 57 Inserts

### Recommended abrasive belts:

Speciality abrasive cloth belts with rubber backing. Grade L4 or L5.

See page 10.

Speciality abrasive flap belts with rubber backing. Grade L1.

See page 10.



*Drawing showing four belts for upper side and four belts for lower side of plate, allowing top and bottom de-slagging in one pass.*

## FLAT6 LISSMAC OXIDE REMOVAL MACHINE SBM-B



For removal of oxide layers on sheet and plate dges from cutting with

This machine uses wire belts with individual wire sections mounted on a rubber belt.

### Belt sizes for Lissmac oxide removal machine:

1000 mm wide model  
85 Wire brush Inserts

1500 mm wide model  
114 Wire brush Inserts

### Recommended belts:

Speciality wire belt grade L3, see page 10.



*Drawing showing feed direction of conveyor and cross direction of abrasive belts.*

**FLAT7  
LISSMAC  
DEBURRING  
AND EDGE  
ROUNDING  
MACHINE  
SBM-S**



Model SBM-S is the standard model for deburring and edge rounding. It has 4 abrasive flap belts and can cope with most burrs.

**Belt sizes for Lissmac Model SBM-S**

**1000 mm wide model**  
Combi flap belt: 43 Inserts

**1500 mm wide model**  
Combi flap belt: 57 Inserts

**Recommended belts:**  
Speciality abrasive flap belts, grade L1 or L2, see page 10.



*Drawing showing feed direction of conveyor and cross direction of abrasive belts.*

**FLAT8  
LISSMAC DEBURRING AND EDGE  
ROUNDING MACHINE  
SBM-L**



Model SBM-L is the heavy duty version of Model SBM-S. In addition to the 4 abrasive flap belts it has an abrasive belt which will remove even heavy burrs.

**Belt sizes for Lissmac Model SBM-L**

**1000mm wide model**  
Abrasive belt:  
Combi flap belt, see page 10.

**1500mm wide model**  
Abrasive belt:  
Combi flap belt, see page 10.

**Recommended belts:**  
Speciality abrasive flap belts grade L1 or L2 plus speciality abrasive belt grade L4 or L5, see page 10.

**FLAT9  
OVERHEAD BELT GRINDERS**



**Abrasive belt sizes for overhead belt grinders**

Model L84/1480	3850mm - 3950mm x 100mm
Model L85/2000	5500mm - 5600mm x 150mm
Model LS90/2000	6000mm - 6200mm x 150mm

**FOR MEDIUM TO HEAVY DUTY GRINDING**

General purpose belt for medium to heavy duty grinding of all metals with moderate stock removal rates.

Mounted on serrated contact wheels from 50 to 75 shore hardness  
X weight from grit 60 to grit 120  
J weight from grit 150 to grit 400  
Aluminium Oxide or Zirconia. See pages 3 - 4.

**FOR LINISHING**

General purpose belt for grinding and finishing of most metals with light to moderate stock removal rates. Particularly well suited for non ferrous metals.

Mounted on serrated contact wheels from 30 to 65 shore hardness.  
J weight from grit 60 to grit 400  
Aluminium Oxide or Zirconia. See pages 3 - 4.

**FOR FINISHING**

Conglomerate abrasive belt for precision finishing to very fine tolerances. See page 5.



# GENERAL ABRASIVE BELT INFORMATION

## THE MANUFACTURING PROCESS FOR COATED ABRASIVES

### Definition of Coated Abrasive Products

All coated abrasives products start off as jumbo rolls and are then cut to shape and size to make up belts, discs, wheels, etc.

### HOW COATED ABRASIVES ARE MADE

#### A simplified version of the manufacturing process

The interesting part of the making of Coated Abrasives is that for most products the minerals are not dropped on to the resin coated backing but that minerals pass through an electrically charged field which propels them upwards toward the backing and bond.

This electrostatic system ensures that each abrasive mineral is pulled up in such a way that it is firmly anchored and orientated to leave the sharpest edges positioned for max. cutting efficiency..

Two coats of bond are applied. One to adhere the mineral to the backing and one to firmly secure it.

In the early days of manufacture of coated abrasives glue was the bonding agent. Later resin over glue became the fashion and now resin over resin is the standard method.

To further improve bonding and lubrication some coated abrasives receive a third coat or grinding aid and lubricants which improve the cutting characteristics and reduce heat.

Bonded abrasives have grain arranged at random and therefore do not cut as well as coated abrasives.

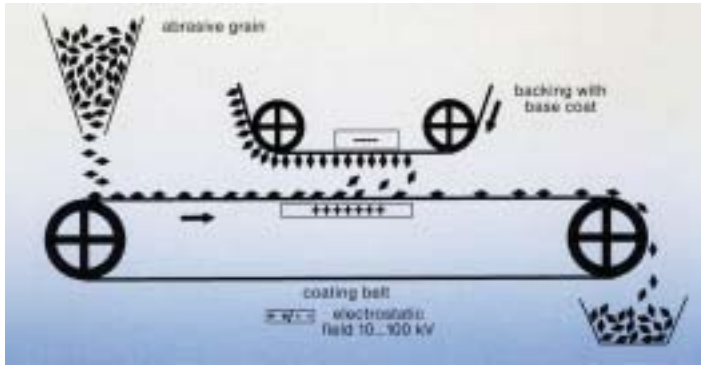

## THE PARTS THAT MAKE UP COATED ABRASIVE BELTS

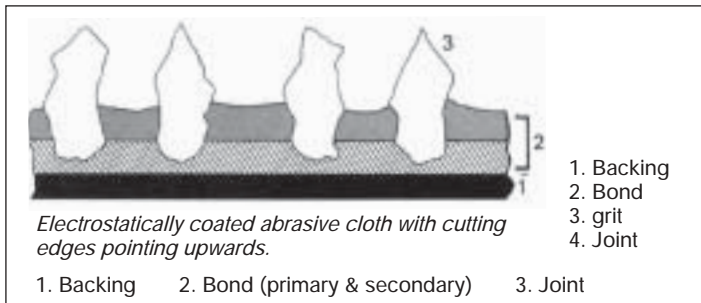

*Backing, Bond and Minerals are the three main parts of Coated Abrasives.*

### Backings

Backing can be cloth, paper, vulcanized fibre or film. Non woven nylon is also used but it is strictly speaking not a backing material because it is impregnated with abrasive mineral.

### PAPER

With the exception of some applications with random orbital sanders, overhead belt grinders (pad sanders) and wide belt machines paper backed abrasives are rarely used for finishing metals. We have therefore omitted detailed descriptions.

Paper comes in a variety of grades with A being the thinnest and most supple to F being the thickest and toughest.

### VULCANISED FIBRE

Consists of many layers of polymer impregnated paper.

Used exclusively for fibre discs on portable abrasive power tools.

### CLOTH

Cloth for Coated Abrasives goes through a complex manufacturing process to make it suitable for the many demands made on it and the many grades needed for the various abrasive belt grades. From being as soft and flexible as a handkerchief to being strong and tough enough to survive contact pressures from a 50 KW motor.

Special treatment ensures that belts made from abrasive cloth do not stretch.

### Bonds

The bond holds the abrasive mineral to the backing. Its purpose is to allow the mineral to fracture at a controlled rate, forming new cutting edges and thereby making the belt cut effectively throughout its life.

Choosing a belt with a weak bond for high contact pressure grinding will result in the mineral being stripped off the backing prematurely. Choosing a strong bond for manual grinding will result in the belt glazing and losing its cut because the contact pressures that can be applied by hand are too low.

In early abrasive products the mineral was attached to the backing by animal glue but even the best glue could not prevent minerals from shedding at a fast rate.

The next step was synthetic resin over glue bonding which for many years was accepted as the best bond system until resin over resin took over.

### Mineral (Grit)

Minerals are the cutting media on coated abrasives. They can be classified into natural minerals and man made minerals:

**Natural minerals are glass, emery, garnet and flint.**

Natural mineral abrasives are rare and difficult to obtain. Natural minerals do no longer play a part in grinding metals.

**Man made minerals are: aluminium oxide, zirconia, silicon carbide, ceramics, diamonds.**

For more information on mineral grades and for the Mohs hardness comparison scale on page ??

All traditional minerals are available in a wide range of grit sizes, in accordance with the standards laid down by FEPA, the Federation of European Producers of Abrasives. FEPA grit sizes are often prefixed with the letter P. FEPA P grits are different from American grit sizes:

24,30, 36,40, 50, 60, 80, 100, 120, 150, 180, 220, 240, 280, 320, 360, 400, 500, 600, 800, 1000, 1200

Finer grits are only available with Microfinishing film, structured abrasives and diamonds.

See comparison chart on page ... for more details



## Gritty says . . .

*Synthetic minerals and man made fibres have replaced natural minerals and cotton in almost all abrasive belts.*

## HARDNESS SCALE OF MINERALS

### The Mohs scale

The Mohs scale measures the hardness of minerals. It has values from 1 to 10. Each mineral higher up the scale is capable of scratching the mineral just below it. Talc is the softest at 1 and diamond the hardest at 10.

1	Talcum	7	Quartz
2	Gypsum	8	Topaz
3	Calcite	9	Corundum
4	FluorspaR	9.4	Synthetic aluminium oxide
5	Apatite	9.6	Silicon carbide
6	Felspar	10	Diamond

Although being by far the hardest mineral diamond is uneconomical for machining steel because the chemical reaction between the iron in steel and the carbon in diamonds causes fast wear. Cubic boron nitride does not react with iron and is therefore the superior mineral for machining steel.

Cubic boron nitride is rarely used for coated abrasives. Instead a new range of super abrasives has taken over.

## MATERIAL HARDNESS VALUES COMPARED WITH MINERAL HARDNESS AS PER MOHS SCALE

VICKERS	BRINELL	ROCKWELL B	ROCKWELL C	ROCKWELL M	ROCKWELL R	MOHS
						10
						9
						8
	1000		80			
1000						7
	500					
500			40			6
		120				5
		100	20			
200	200		0			4
		80				
100	100	60				
		40				
		0		140		
50	50			120		
				100		
				80		2
20		20		60		
					130	
				40	120	
				20	100	
					80	
5	5					
					40	
						1

The comparison values above are intended as a general guide only.

### FEPA grit Description

#### P 24, P 36

**Extra coarse.** Coarsest grits available for metal grinding. For special purpose grinding only. These very coarse grits rarely result in higher stock removal rates than grits 40 and 60.

The grits are coarser but there are less of them on a given area. The finer grits like 40 and 60 have more cutting edges and remove the same amount or more metal.

#### P 40, P 60

**Coarse.** For most grinding operations these two grits are the coarsest necessary for high stock removal.

#### P 80, P 120

**Medium.** A good starting point for most multi-stage grinding and finishing operations.

#### P 180, P 220, P 240, P 280

**Fine.** Often sufficient for a final finish. Popular for graining of stainless steel.

#### P 320, P 400, P 500, P 600

**Very fine.** For finishing of many parts prior to plating or prior to buffing. Grit 320 is the coarsest finish for subsequent polishing with sisal and cotton buffs.

#### P 800, P 1000, P 1200

**Ultrafine.** The finest abrasive grit sizes for standard traditional coated abrasives. Limited availability. Most standard abrasive belts are available up to grit 600 only. But there are some special grades up to grits 800, 1000 and 1200. If you need finer grit sizes than are available from standard abrasives you can use structured abrasives which are available up to approx. grit 2500.

## ABRASIVE BELTS BY MINERAL AND TYPE

In Europe the standard grit classification is FEPA and grit numbers are preceded by the letter P.

The USA uses a different grading system called CAMI.

Comparison of Micron values and FEPA P grit.

1 micron is 1 millionth of a metre

### COMPARISON TABLE

FEPA P grit FEPA P grit	Approx. Microns of	Structured abrasives	Ra microns of structured abrasives grit on stainless	Compact grain	CAMI grit, approx.	Microfinishing film grit in microns	Nickel plated diamond grits, approx.
24	740						
30	625				30		
36	525				36		
40	412				40		
50	326	500			50		
60	260	400			60		
							250
80	197	300					
100	156				80		
120	127	160					
							125
150	97	130			120	100	
180	78	110	1.10		180	80	
220	60	100	1.00		220		
							74
240	59	80	0.85			60	
280	52	65	0.70		240		
320	46	60	0.60				
360	40					40	
							40
400	35	45	0.45		320		
500	30	40					
600	26	30	0.29		360	30	
							20
800	22						
1000	18	20			500/600	15	
1200	15	16	0.15				10
2000	10	6	0.06		1000		
3000	5						
3500	3						
8000	3						
50 000	0.5						

## ABRASIVE BELTS..... the alternative cutting tools

Abrasive belts are made from jumbo rolls of coated abrasives.

The jumbo rolls, which can be up to 1600 mm wide are slit into narrower rolls.

A typical width is 300mm. At this width the rolls are cut to length and joined into endless belts.

These 300mm wide belts are then cut down to the final required width, i.e. 50mm, 100mm, 150mm, etc.

Smaller belts for portable abrasive power tools. 6mm, 12mm, 19mm, 25mm wide x 465mm, 610mm and 710mm long are made in the same way but cut to final size on special machines.

The vast majority of abrasive belts have straight edges but for some special applications it is possible to cut belts with wavy edges. The wavy edges will allow belts to be used for grinding radii without cutting into the metal.

Abrasive belts are the most efficient and most economical cutting tool for grinding, deburring and finishing most materials, as long as you choose the correct type, grade and grit from the thousands of specifications available.

There are abrasive belts which can remove material faster than most other methods and there are grades which can grain, satinize or polish to a pleasing decorative finish or level the surface smooth enough for even the most demanding plating operation.

The latest Engineered Belts can finish just short of a mirror polish and for many applications shorten belt sequences worked out with traditional belts.

If you have been using the same abrasive belts for the last 5 years you may be losing out on the benefits and cost reductions the very latest belt grades offer.

Abrasive belt technology does not stand still and some significant advances have been made during the last 5 years.

***If your consumption of belts is a substantial cost factor in your business we can investigate, test and advise how you can reduce costs.***

## WHY ABRASIVE BELTS CUT FASTER, FINISH FINER AND LAST LONGER

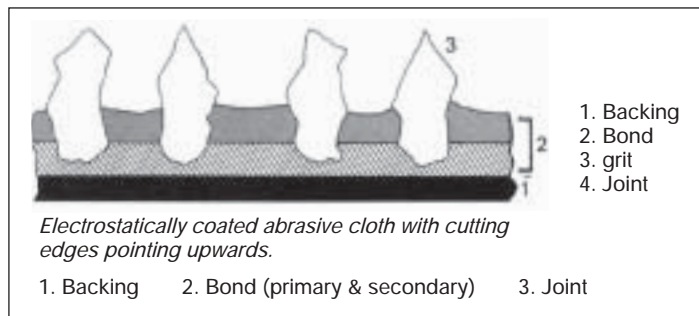

### Electrostatic coating

In the electrostatic coating process the adhesive coated backing and the abrasive grains pass through an electrically charged field which propels the abrasive grains upwards towards the backing. The grains are embedded in the adhesive with the sharpest edge of the abrasive grains exposed.

The demands on the resins used to bond the abrasive minerals to the backing are very high. Most manufacturers use phenolic resins and the top coated abrasives manufacturers formulate their own resins.

Two coats are used. One to adhere the mineral to the backing and one, applied over the mineral, to firmly secure it.

Common descriptions are resin over glue, where the first coat is glue and the second resin or resin over resin, where both coats are resin.

To further improve bonding and lubrication some coated abrasives grades receive a third coat of grinding aids and lubricants which improve the cutting characteristics and reduce heat.

Grinding = stock removal

Finishing = improvement of surface finish

With abrasive belts the minerals which do the cutting are electrostatically coated on to the fabric backing, each one accurately arranged with the sharpest point upwards and ready to cut. The minerals on abrasive belts are self sharpening and wear at a consistent rate to form new cutting edges.

To achieve this consistent wear rate over a long period requires careful tuning of all the factors influencing it: cutting speed, shore hardness and grooving of the contact wheels and applying the correct contact pressure.

As a result abrasive belts cut faster and cooler, remove more material and finish smoother and more uniform than bonded wheels which have their minerals randomly arranged.

If minerals do not wear the abrasive belt will glaze and lose its cutting ability. You do not get the full value out of the belt and you need to seek advice on how to improve your set up.

Abrasive belts with their thousands of cutting edges can outperform grinding wheels, milling cutters, scurf mops, rotary files, carbide burrs, mounted points and other cutting tools for many grinding, deburring and finishing operations. Stock removal rates are higher in most cases and abrasive belts can cut hard metals which milling cutters and other tools cannot.

When it comes to high stock removal coupled with quality of finish abrasive belts are unbeatable.

### Abrasive belts can cut all materials

There are virtually no materials that cannot be ground with abrasive belts.

Aluminium Oxide, Silicon Carbide and Zirconia abrasive belts grind most metals,



Ceramic abrasive belts grind even the hardest materials. Abrasive belts can be used for grinding...

### Quick change for best grade and grit

Abrasive belts can be changed in seconds without specific skills. This means that for each job the best grade and grit can be used. This is in contrast to bonded wheels which take a long time to change and which need qualified operators to carry out changes. Abrasive belts cause less vibration and are far less dangerous when breaking than grinding wheels.

### Even robots use abrasive belts

There is no better tool than an abrasive belt for use in robot cells for grinding, deburring and polishing.

Belts for robot cells are up to 5000mm long to reduce belt changes.



### Abrasive belts reach difficult to grind areas

Abrasive belts can grind, deburr and finish areas that are inaccessible for other tools.

Reduced vibrations and safer working.

There is no dangerous flying debris from a broken abrasive belt. If a belt breaks it loses its kinetic energy and is usually contained inside the guard.



Abrasive belts run on rubber coated contact wheels with greatly reduced vibrations.

### Representing the future

Progressive Companies worldwide use abrasive belts to improve grinding, deburring and finishing operations.

### Dry or wet operation

Abrasive belts can be used dry or wet with a coolant. Wet operations slightly reduce stock removal rates, but on multihead machines this is immaterial. If multihead machines are run dry the heat distorts parts and damages the surface. Coolant reduces heat, cleans the belt, prolongs the life of the belt and produces more even and finer finishes.

## ABRASIVE CLOTH BELT BACKING GRADES

Available from soft for finishing of highly contoured parts (eg sanitary fittings) to extra heavy and stiff (for power grinding).

The flexibility of the belt has to be matched to the flexibility of the contact wheels.

This is a list abrasive belt cloth backing grades as described by various manufacturers. Some of these descriptions are for the same type of backing. Surtech has therefore reduced the descriptions to the main types of backings.

### XX weight

Very heavy. Stiff. Cotton cloth.

### Z-weight

Very heavy, very stiff. Synthetic cloth. Available in coarse grits only. For extra heavy duty grinding with high contact pressures. Use with very hard contact wheels 70 to 90 shore.

### TY-weight

Very heavy. Medium flexible. Synthetic cloth.

### Y-weight

Heavy, stiff and very sturdy. Usually polyester fabric for extra toughness. For extra heavy duty grinding. Available in coarse grits only. Use with hard contact wheels from 80 to 95 shore hardness.

### X-weight

Sturdy. Usually polyester fabric for extra toughness. Stiff. For heavy duty grinding. Available in coarse and medium grits only. Use with hard contact wheels from 65 to 80 shore hardness.

### X-flex-weight

Heavy. Flexible. Cotton cloth.

### J-weight

Light and flexible. For coarse to fine grinding where slight conformability is required. Available in all grits from coarse to fine. Use with contact wheels from 40 to 60 shore hardness.

### J-flex-weight

Very flexible. Cotton fabric. The most flexible cotton grade. For grinding of contoured parts with moderate stock removal rates. Available in all grits from coarse to fine. Use with contact wheels from 20 to 40 shore hardness.

### F-weight

Very flexible. Ideal for heavily contoured parts. use with contact wheels from 20 to 45 shore.

### T-weight

Cloth. Extremely flexible.

## Abrasive belt joints

Over the years many types of joints have been used. Some of the early joints caused bumps and wore rapidly. Joints breaking was a regular occurrence.

Only since better adhesives became available and joints were backed by thin polyester film breaking joints and bumps have become extremely rare.

The standard joint is now the skive joint described below.

### Skive joints

Skive joints are used on the vast majority of abrasive belts. They usually run at 45 degrees and are either overlapped and glued or butted and interleaved with film.

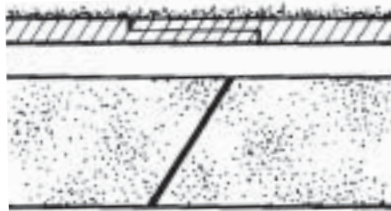

## RECOMMENDED CUTTING SPEEDS FOR ABRASIVE BELTS

m/sec into sfpm (feet per minute)

m/sec	sfpm
10	1968
15	2952
20	3936
25	4920
30	5904
33	6494
35	6888
38	7478
40	7872

### Recommended cutting speeds for non woven belts

Cleaning oxide and other coatings	33 - 38 m/sec
Satin finishing	10 - 20 m/sec
Deburring	25 - 35 m/sec

MATERIAL	M/SEC	MATERIAL	M/SEC
Acrylics	3 - 8	Stone	30 - 35
Sintered carbide and Tungsten carbide	8 - 12	Wood	20 - 25
Plastics	10 - 20	Inconel	15 - 20
Glass	13-18	Nickel/chrome	13 - 18
Aluminium	35-45	Rubber (hard)	25 - 36
Brass	25 - 40	Stainless steel	25 - 35
Copper	20 - 25	Carbon steel	25 - 30
Grey cast iron	30 - 40	Titanium	10 - 15
		Tool steel	20 - 25

These cutting speed recommendations are a rough guide only.

The most effective and most economical speed will depend on the shape of the part, the type of contact wheel used and the max. temperature the part can stand.

To find out the most efficient and most economical cutting speed you should use variable speed machines



## HOW TO CALCULATE ABRASIVE BELT SPEEDS

Abrasive belt cutting speeds are determined by the speed of the drive motor and the diameter of the drive wheel.

The drive wheel is the wheel that is attached to the motor.

### 2 wheel machines

An abrasive belt backstand machine is a two wheel machine where the drive wheel is also the contact wheel. The second wheel is the idler wheel, which tensions and tracks the belt.

The Cutting speed is determined by the motor speed and the contact wheel diameter.

There are also two wheel abrasive belt grinders with the drive wheel at the rear and the contact wheel at the front.

The rear drive wheel diameter and the motor speed determine the belt speed.



### 3 wheel machines

With 3 wheel abrasive belt machines the drive wheel is almost always at the bottom rear. The idler is at the top rear and the contact wheel at the front. The bottom rear drive wheel and the motor speed determine the belt cutting speed.



### 4 wheel machines

With 4 wheel abrasive belt machines the drive wheel is almost always at the bottom rear. The other 3 wheels, at the top rear, the top front and the bottom front are idler wheels. A contact platen or contact wheel can be fitted between the front top and bottom idler wheels. The abrasive belt cutting speed is determined by the rear bottom drive wheel size and the motor speed.



The advantage of all abrasive belt machines where the drive wheel is not the contact wheel is that the contact wheel diameter can be changed without changing the abrasive belt cutting speed.

Thus on a typical independent drive machine the contact wheel can be from 50mm diameter to 200mm diameter with the abrasive belt cutting speed remaining the same.

## FACTORS INFLUENCING COATED ABRASIVE BELTS PERFORMANCE

### Scratch pattern and cutting speed

#### Grit size and cut

In general coarser grits remove more stock faster. However, this rule applies less to grit sizes 36 and 24. There is little more stock removal from grits 36 and 24 than from grit 40. The reason for this is the amount of cutting edges. Grits 36 and 24 are coarser than grit 40 but they have less cutting edges and therefore the stock removal rates of grit 40 are as good as those of grits 36 and 24, in most cases.

Used belts of the same grit size produce a finer finish than new belts. The rule is that the first 30% of a belt's life produces a coarser finish and then settles down to a finer finish for the remaining 70% belt life.

#### Belt speed and finish

A faster belt speed results in a finer finish. Abrasive belts run at faster speeds generally last shorter than slower run belts.

This effect is more pronounced with coarse belts up to approx. grit 120 and less pronounced with fine belts from grits 150 to 400.

#### Belt speed and cut

For many metal grades the rule "the higher the belt speed the higher the rate of cut" applies, with the proviso that 45 m/sec is the max. safe speed for belts and contact wheels.

32 - 38 m/sec is the belt speed of the majority of abrasive machines.

For some hard metals slower speeds, down to 25 m/sec will produce higher stock removal rates.

### Coolants and belt life, Coolants and finish

Coolant can dramatically increase belt life and improve finish.

A dry belt will initially cut faster but will then lose its cutting ability fast.

A wet abrasive belt will carry on cutting much longer than a dry belt.

### Abrasive belt sequence

Each grinding and polishing sequence has to be established individually and based on the finish of the part before and the finish required after.

Badly scratched parts or rough castings may need to be ground with grit 40 first. A tube or sheet may need a grit 120 to start. Whatever grit you use first it has to be capable of removing the surface imperfection. Thereafter all subsequent grits have to remove the scratches of the previous grit.

As a rule of thumb do not jump more than 2 grits or you may find that at the end of the sequence you still have scratches left from the first or second operation and you will have to start all over again.

A typical sequence is 1. grit 60, 2. grit 120, 3. grit 180, 4. grit 320, 5. sisal buff and cutting compo, 6. cotton buff and colouring compo for a mirror finish. By using belts finer than grit 320 you can cut down on polishing with sisal and cotton buffs.

### Plating

When parts are plated after grinding it very much depends on the quality of finish required how fine a grit should be used before plating. Some are satisfied with grit 240 or grit 280, but some fine scratches will be visible after plating.

To improve the finish from a grit 240 or 280 belt you can apply grease or compo to the belt (also called bobbing grease). The resultant finish will then be nearer that of a grit 400 or 600 belt or even a buff.

For an almost scratch free finish after plating you need to use structured abrasive belts. For an absolute mirror finish after plating you have no choice but to polish with a buff after abrasive belt finishing.

The plating process itself also influences the finishing sequence. If you formulate your plating to level more you can finish a little rougher.

You have a choice of spending more time on finishing or more money on plating.

### Powder coating

Powder coating does not need the same fine finishes as plating. Often abrasive brushes or nylon impregnated abrasives are used rather than belts and grit 120 seems to be a grit that satisfies many.

### New or worn abrasive belts for finishing sequences ?

#### New and worn belt finishes

A used grit 180 belt may well produce the same CLA finish as a new grit 240 belt, but a used grit 180 is still a grit 180 ie larger than grit 240 and as a result a used grit 180 finish will take longer to polish than a new grit 240 finish.

On multihead flatbed conveyor machines or multihead centreless machines abrasive belts can be moved down the line after approx. 50% of their life cycle. This method evens out consistency of finish and improves belt life better than using a grit size per head right to the end of its life.

Most grinding and finishing operations require a sequence from coarse grits to fine grits and from abrasive belts to buffs. You will obviously have to choose a starting grit size that is capable of removing the worst surface imperfection of a given part. You must then choose subsequent grit sizes that are capable of removing all the scratch patterns from the previous operation. If you do not follow this rule you may find that after 4 or five operations you still are left with scratches from the first operation and you then have no choice but to start all over again.

In any abrasive belt sequences do not jump more than two grits. ie. start with grit 60, then grit 120, 180, 240, 320. After grit 320 buff with sisal and cutting compo, followed by buffing with cotton and colouring compo.

The coarsest finish that can be polished with a sisal buff is grit 320. Grit



A typical coolant tank with pump and paper filter

400 or a greased grit 320 would be better. If you are not happy with the finish from the sisal buff you will have to follow it with one or even two cotton buff finishes.

## ABRASIVE BELT TRACKING

Almost every belt grinder has a different method for tracking abrasive belts, however the principal rules are the same.

Belt grinders have up to 4 wheels: 1. The contact wheel, 2. The idler wheel (s), 3. The drive wheel. Some machines, ie those with a platen only (linishers) and those for work on the slack of belt (Model 213) have no contact wheel - only a drive wheel and idler wheel(s).

### Contact wheels

Contact wheels generally have a flat face. When new the two edges sometimes have to be lightly radiused, otherwise the belt will run off. To radius the edges use a piece of abrasive cloth attached to a wood or metal backing.

In some rare special cases the contact wheel will have to be crowned. Ask your machine supplier how best to carry this out.

Contact wheels are available with a wide range of tyres: rubber, polyurethane, foam, canvas, etc.

The hardness can vary from around 20 shore = very soft to 90 shore = very hard. The hard wheels are easier to tension and to track. The very soft contact wheels can distort under too high tensioning and then tracking will be difficult. Hard contact wheels should have no problems being run at high speeds. Soft contact wheels may have to be run at slower speeds.

When very narrow abrasive belts and very narrow contact wheels are used, ie from as narrow as 5mm to 10mm it is very difficult to keep the abrasive belt on the contact wheel. The initial shock of the starting motor can throw the belt off. In such cases a soft start or better still an inverter is recommended.

### Drive wheels

On some machines the drive wheel, ie the wheel mounted on the motor shaft is also the contact wheel. Treat this in the same way as described under contact wheel.

Where the drive wheel is not the contact wheel the wheel is lightly crowned. This crown is important because the abrasive belt always runs towards the highest point. This crown can wear and when this begins to affect the belt tracking the wheel will have to be re-crowned.

### Idler wheels

All idler wheels also have to be lightly crowned.

### Tensioning

Abrasive belts have to be tensioned correctly to facilitate tracking. Tracking controls can be manual or pneumatic. With too little tension the belt will run off or slip on the wheels leading to premature wheel wear. With too much tension the belt can break. For most operation tensioning the belt to "drum tight" is the best setting. Where extremely soft contact wheels or very narrow belts are used you need to experiment a little to get the right tensioning setting. Narrow belts can stretch and require occasional re-setting.

### How to check proper abrasive belt tracking

Fit belt. With machine switched off manually pull the belt around the wheels as fast as you can. Check if it centres and runs true. If yes switch on machine and immediately switch off again. If the belt still runs true the machine is ready to be used.

Proper tensioning also helps with the belt running properly. We recommend a "drum tight" tension.

With proper adjustment and settings of tensioning and tracking the belt must move very slowly to the right or left depending on which way the tracking control is turned. If the belt jumps suddenly to either side then there is something wrong with the tracking system and settings.

### Good housekeeping

Make sure all wheels are clean on the outside as well as inside the rim.

### Short term fix

When a drive or idler wheel is worn concave you can as an emergency measure run a few layers of self adhesive tape, approx. 1" wide around the centre of the OD. This usually brings the abrasive belt back to running centrally.

## CONTACT WHEELS

### INTRODUCTION

#### The importance of contact wheel selection

Next to the abrasive belt, correct choice of the Contact Wheel is the most important factor affecting performance of belt grinding, deburring and polishing operations.

SURTECH contact wheels are designed to maximise abrasive belt performance. Worn contact wheels and the use of the wrong contact wheel type reduce abrasive belt efficiency and affects abrasive belt tracking.



#### Finishing

A soft, 45 shore contact wheel, with 2: 1 land to groove ratios and rectangular tapered lands. For J and Flex weight abrasive belts in grits from 120 to 400. For fine finishing with little stock removal.

#### General Purpose Grinding And Finishing

A medium hard, 65 to 70 shore contact wheel, with 1: 2 land to groove ratios and rectangular square lands.

For all grades of abrasive belts and all operations requiring aggressive cutting action and an even finish.

#### High Stock Removal

A hard, 85 to 90 shore contact wheel, with buttressed lands. (1: 2 land to groove ratio).

For X and Y weight abrasive belts in coarse grits from 36 to 80. For high stock removal and maximum aggression.

For grinding to close tolerances.

This wheel must be run in one direction only - see drawing.

### Contact wheels - Some rules of thumb

A small diameter contact wheel removes more stock than a large diameter contact wheel. A large diameter contact wheel produces a finer finish than a small diameter contact wheel.

Small diameter contact wheels produce shorter scratch patterns than large diameter contact wheels.

Shorter scratch patterns are easier to buff than long ones.

The harder the contact wheel the higher the stock removal.

Softer contact wheels produce finer finishes than harder contact wheels.

Serrated contact wheels are more aggressive than smooth contact wheels. Varying the land to groove ratio of serrations can increase effective contact pressures by more than 100 %.

### Contact area and finish

The harder the contact wheel, the faster the cut and the coarser the finish.

The smaller the contact wheel diameter, the faster the cut and the coarser the finish.

Finish and rate of cut usually go hand in hand. Coarser finishes are achieved at a high rate of cut and the fine finishes at a lower rate of cut.

High speeds give better finishes. Serrated contact wheels retard glazing of abrasive belts and prolong belt life.

### Contact wheel sizes

Contact wheels for manual abrasive belt grinding are available from 12mm to 450mm diameter.

Some portable abrasive belt grinders use contact wheels down to 25mm diameter and 25mm wide.

Contact wheels on Power Grinders can be up to 600mm in diameter.

The narrowest abrasive belt of 3 mm width and running on a tapered contact wheel 25mm diameter and approx. 1mm wide can be used on a portable abrasive belt file. The widest abrasive belt can be over 2000mm wide running on contact wheels of the same width as the belt.

The majority of contact wheels have a rubber tyre, but contact wheels are also available with canvas, leather, plastics, polyurethane and foam tyres. In some special cases contact wheels can be made of steel for max. abrasive belt aggressiveness. Some portable tool contact arms have steel contact wheels, however, these are not meant as contact wheels but rather as idlers. Work is supposed to be carried out on the slack of the belt or the platen.

Contact wheel hardness is expressed in shore or durometer. Shore hardness alone is not the correct measure for contact wheel hardness. A 60 shore contact wheel with smooth (plain) surface is less aggressive than a 60 shore serrated contact wheel. A 30 shore serrated contact wheel is softer than a 30 shore smooth contact wheel.

## Contact wheels, plain and with serrations

Contact wheels are available plain or in dozens of different serrations. We have standardised serrations and shore hardness to give you the best abrasive belt performance in over 80 % of all applications.

### 1. Plain face

**2. 2:1 land to groove ratio for contact wheels from 30 to 50 shore**  
Use with abrasive belts J and J-flex in grit sizes 120 to 400.

For fine finishing with little stock removal.

**3. 1:1 land to groove ratio for contact wheels from 60 to 75 shore**

For general purpose grinding and finishing.

For all grades and all grits of abrasive belts. For all operations requiring an aggressive cutting action and an even finish.

**4. 2:1 land to groove ratio for contact wheels from 70 shore to 90 shore**

For aggressive grinding where high stock removal rates are more important than finish. One of the most aggressive contact wheel construction that still keeps well within vibration limits.

### 5. Buttress tooth formation

For contact wheels from 75 to 95 shore.

For many operations the most aggressive contact wheel construction that still keeps within vibration limits. For aggressive grinding with coarse belts Y weight and X weight from grit 36 to 60.

## Contact wheel hardness

Expressed in shore or durometer

**20 - 35 shore** Very soft. For highly contoured parts. Use only with J-flex belts in fine grits from 180 to 400.

**40 - 55 shore** Soft. Can easily be depressed by thumb. For slightly contoured parts or for fine finishing of flat parts.. Use with j-flex or flex belts from grit 120 to 400.

**60 - 75 shore** Medium. Can be depressed with finger nail. The most popular contact wheel hardness. For general purpose grinding of most parts and with all abrasive belt types, grades and grits.

**80 - 95 shore** Hard, cannot be dented by finger nail. For aggressive grinding of flat parts with coarse abrasive belts in grits 36 to 80 and in x and Y weight.

Choose the hardest possible wheel to suit the shape of the part. Harder wheels make the abrasive belt work more aggressively and prolong belt life.

Contact wheels must not be run at a surface speed in excess of 45 m/sec. The surface speed is determined by the drive wheel. There are two ways to establish the speed:

### A. When the contact wheel is also the drive wheel:

Check the rev/min of the drive spindle. Read off the surface speed under the dia. of the contact wheel.

### Examples:

a) A typical drive spindle running at 2800 rev/min and fitted with a contact wheel of 250mm diameter results in a surface speed of 36.6 m/sec. – acceptable for most grinding operations.

b) A drive spindle running at 1400 rev/min and fitted with a 200mm diameter contact wheel has a surface speed of 14.7 m/sec. - too slow for most grinding operations.

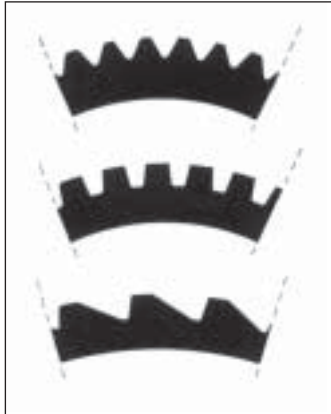
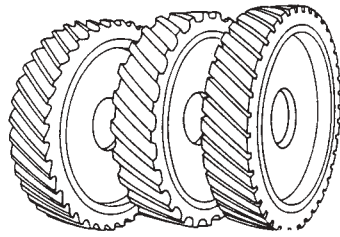

c) A drive spindle running at 2800 rev/min and fitted with a 350mm contact wheel results in a surface speed of 51.3 m/sec – well above the recommended speed and dangerous.

### B. When the drive wheel is not the contact wheel:

Follow the above recommendations but use the diameter of the drive wheel not the contact wheel for calculating the surface speed.

## Table of Surface Speeds

Diameter of contact wheel in mm	150	200	250
at 900 rpm	7	9	12
1200 rpm	9	13	16
1400 rpm	11	15	18
1800 rpm	14	19	24
2400 rpm	19	25	31
2800 rpm	22	29	37

The above recommendations concern safe operating speeds only. Speeds in excess of 45 m/sec are unsafe. Our contact wheels are tested to 45 m/sec and under no circumstance must they be used in excess of this speed.

The recommended economical cutting speeds are determined by the type of abrasive belt and the material being ground. They are quite different from the max. safe speeds.

## CONTACT WHEEL TYPES

### TYPE GL



A contact wheel with a smooth (plain) rubber tyre, otherwise the same as GS.

Recommended for medium to fine finishing with abrasive belts grit 120 and finer. The smooth tyre reduces belt life.

### TYPE GS



The most widely used contact wheel. Same tyre as GI but serrated to prolong belt life. Available in 40, 60 and 80 shore hardness as standard.

Available in 30, 70, 90 shore hardness to order.

From 100mm dia to 450mm dia. From 25mm wide to 150mm wide.

## TYPE CTP/1



Similar to Type GS but with the much harder wearing polyurethane tyre. More expensive than rubber tyred contact wheels. With a solid polyurethane tyre.

Available in 40, 60, 70, 80 and 90 shore hardness. From 100mm to 450mm dia. From 25mm wide to 150mm wide.

We recommend the use of polyurethane wheels with 90 shore hardness in preference to rubber wheels for all grinding operations requiring an aggressive, long lasting wheel used with abrasive belts grit 36 to 60.

## TYPE VLS



This is the best contact wheel for finishing non ferrous metals and parts with a contoured surface. Widely used on manual and automatic machines as well as in robots cells.

With a polyurethane foam tyre which conforms well and improves abrasive belt performance.

Leaves a smooth, shadow free finish. The polyurethane foam tyre transmits vibrations considerably less than a rubber tyre.

Not suitable for heavy duty grinding as the polyurethane foam tyre is heat sensitive.

Available in shore hardness 25, 35 and 45. Available from 100mm to 450mm dia. Available from 30mm to 150mm wide.

## TYPE PS

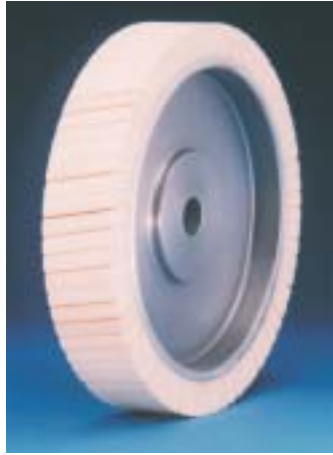

This is our softest contact wheel. Available in 20, 40, and 50 shore.

Consists of alternating flaps of sponge rubber and canvas.

Conforms well even to extreme contours when used with j-flex abrasive belts.

Benefits from variable speeds. Softer when run at low speeds up to 1400 rpm. Harder when run at fast speeds over 1400 rpm.

From 250mm to 500mm dia, from 30mm to 150mm wide

## TYPE RE



An expanding rubber wheel which allows you to turn a polishing machine without belt arm into an abrasive belt grinder.

The abrasive belt, also called sleeve, is held in position by the rubber tyre which expands with speed.

From 75mm to 200mm dia. From 38mm to 150mm wide. Shore hardness 40.



**Gritty says . . .**

*Hardness of contact wheels is not the only criteria for good belt performance. The design of the contact wheel serrations are equally important.*



*An expanding rubber contact wheel with an abrasive belt fitted. For more detailed information see page...*



*A pneumatic contact wheel without abrasive belt.*

A pneumatic tyre with an aluminium hub. Available in many sizes. The tyre can be inflated to the required hardness.

The aluminium hub comes with a bore suitable for the machine.

Most popular with the ROTO-SAT type of portable abrasive power tool but also suitable for some bench and pedestal machines. bench

For more detailed information see page ...

## DEDICATED CONTACT WHEELS

We can offer a range of over 10 different types of contact wheels with canvas, foam and tyres from 20 shore to 95 shore hardness.

We can also offer pre-shaped contact wheels with convex or concave tyres.

All of these contact wheels are made to order and can have fairly long delivery times.

## CONTACT WHEELS FOR ROBOT GRINDING AND LINISHING CELLS



Contact wheels used with robot grinding and finishing cells are very similar to those used for manual abrasive belt grinding and yet differ in some important details.

Professionally designed and built robot cells usually have sophisticated constant contact pressure controls. Robots can assert greater contact pressures than human operators, evenly and at all times. Robots do not suffer from "white finger disease"

Robots can often use an abrasive belt of one grit size coarser than that used by an operator. Therefore contact wheels for robot finishing cells are of a slightly different design and slightly harder shore hardness but with dramatically improved results.

Contact wheels for robot cells are designed to suit individual requirements. Surtech can advise on the best specification and can supply contact wheels in accordance with these specifications.

## THE SURTECH CONTACT WHEEL MOUNTING SYSTEM

For wheels from 150mm to 450mm dia.

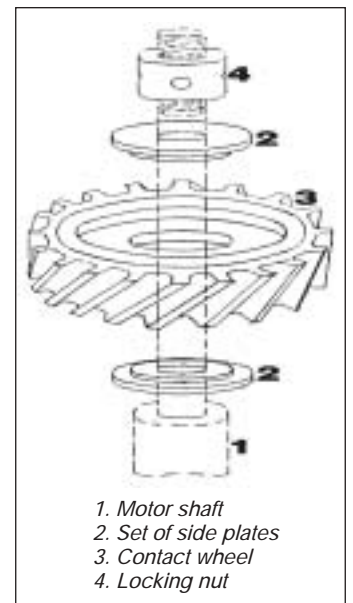

1. Motor shaft
2. Set of side plates
3. Contact wheel
4. Locking nut

SURTECH contact wheels have a standard 65mm centre bore into which the side plates are fitted.

The side plates are then bored out to fit the motor shaft. The locking nut locks everything together.

This system allows us to supply most contact wheels from stock.

## Shaft mounted contact wheels MINI CONTACT WHEELS

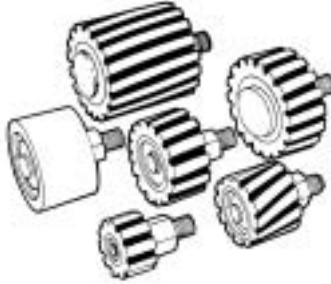

Mini contact wheels are available from approx. 20mm dia to 100mm dia and from approx 6mm to 75mm wide.



There are two designs:

### 1. Metric sizes

With M8 threaded shaft and hexagonal nut to fasten. Available from 20mm to 100mm dia and from 15mm to 50mm wide.

We recommend shore hardness 50. Because of the hexagonal part the shaft on these contact wheels is considerable longer than the impe



### 2. Imperial sizes

With threaded shaft and internal hexagonal bore to fasten.

Imperial size mini contact wheels mounted on their contact arm are narrower than the metric wheels. Available from 3/4" to 4" dia and from 1/2" to 3" wide. We recommend shore hardness 50.

## CONTACT ARM ASSEMBLIES



A simple contact arm assembly for metric mini contact wheels For use on special bench and pedestal machines.



Contact arm assemblies with imperial size mini contact wheels and built in belt tracking controls. For use on special bench and pedestal machines.



A special contact arm assembly with extended reach. Designed for a dedicated pedestal machine.



A selection of contact arm assemblies. Primarily for use with belt files but can also be adapted for use with bench or pedestal machines.

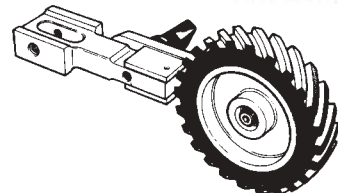
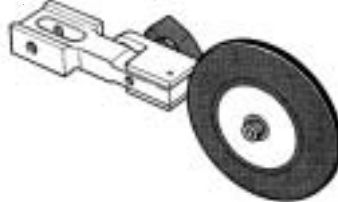
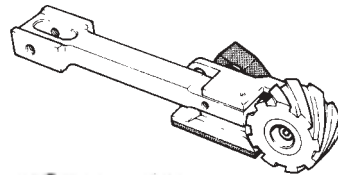

Contact arms complete with contact wheel assemblies



## MORE COMPARISON TABLES

Surface finishes achieved with engineered belts on stainless steel

Engineered Abrasive Grades	SS Finish Microinches	Ra Metric finish
A6	2 - 3	0.6
A16	6 - 10	0.15
A30	10 - 15	0.29
A45	26 - 30	0.45
A65	37 - 39	0.70
A80	39 - 44	0.85
A100	44 - 46	1.00

The surface roughness achieved on stainless steel with various FEPA grits

FEPA	Rz metric
40	28
60	21
100	16
150	13
220	10
280	8
320	5

Particle size in microns	FEPA Grit No
15.3	1200
18.3	1000
21.8	800
25.75	600
30.00	500
35.00	400
40.5	360
46.2	320
52.2	280
58.5	240
65.0	220
78.0	180
97.0	150
127.0	120
156.0	100
197	80
260.0	60
326	50
412	40
524	36
622	30
740	24

## ABRASIVE BELT BENEFITS

### Abrasive Belts

Coated abrasive tools are in many ways superior cutting tools to rotary files, mounted points, bonded grinding wheels, milling cutters, etc.

Abrasive belts are the most efficient and most economical cutting tool for finishing most materials, as long as you choose the correct type, grade and grit from the thousands of specifications available.

There are abrasive belts that can remove material faster than most other methods and there are grades which can grain, satinize or polish to a pleasing decorative finish or level the surface smooth enough for even the most demanding plating operation.

The latest engineered belts can finish just short of a mirror polish and for many applications shorten belt sequences worked out with traditional belts.

If you have been using the same abrasive belts for the last five years you may be losing out on the benefits and cost reductions the very latest belt grades offer.

Abrasive belt technology does not stand still and some significant advances have been made during the last five years. The old products have been upgraded and many new products have been added.

If your consumption of belts is a substantial cost factor in your business, we can investigate, test and advise how you can reduce costs.

### Why Abrasive Belts cut faster, finish finer and last longer

Abrasive belts are cutting tools with thousands of cutting edges. The minerals on abrasive belts are self sharpening. This means they have to wear at a consistent rate to break up and to form new cutting edges.

To achieve this consistent wear rate over a long period requires careful tuning of all the factors influencing it: cutting speed, shore hardness and grooving of the contact wheels and applying the correct contact pressure.

Belts for high pressure grinding are used on machines with up to 75 HP motors. These belts would not perform as well on manual grinding machines with motors from 4 HP to 10 HP.

The technically better belt therefore does not necessarily perform better with manual operations.

### HOW TO SAVE ABRASIVE BELT COSTS BY CHOOSING LONGER BELTS

Abrasive belt prices are made up of the square metre cost plus the cost of the joint. Proportionally the cost of the joint is considerably higher for short belts and lower for long belts.

Many of the abrasive belt sizes in the UK stem from the days of imperial measurements and traditional machine designs:

Imperial	Metric
60" x 2"	1525 x 50 mm
9' x 4"	2745 x 100 mm
11'4" x 4"	3455 x 100 mm
	Etc.

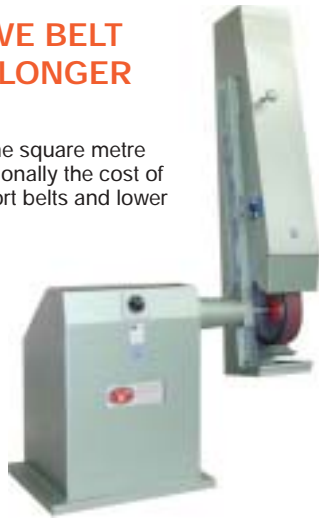

A typical 3500 x 50mm belt grinder

The most popular size used to be 60" x 2". Firstly because that was the size to fit the machines available at the time and secondly because of the practice of using polishing mops and abrasive belts on the same machine. The short belt allowed a fast changeover.

Modern finishing operations no longer combine two operations on one machine and modern machine designs, with improved tensioning and tracking controls, allow the use of longer belts.

The only exception are operations where narrow belts from 6mm to 12mm wide and small diameter contact wheels from 15mm to 25mm are used. In those cases belts lengths of 610mm, 760mm, 1120mm and 1500mm are common.

All other operations are best carried out with belts at least 2000mm long and better still with belts 2500mm to 3500mm long.

The following list shows the savings that can be made by changing from 1525mm long belts to longer belts.



A typical 60" x 2" belt grinder



A typical 2500 x 50mm belt grinder

Belt size	Total area of Abrasive belt you get for your money	Approx Saving compared with 50mm x 1525mm
50 x 1525mm	0.076	
50 x 2000mm	0.1	8.0%
50 x 2500mm	0.125	13.5 %
50 x 3000mm	0.15	17.0 %
50 x 3500mm	0.175	19.5 %

The cost per square m is that of a typical aluminium oxide belt with full resin bond.

## HEALTH AND SAFETY RECOMMENDATIONS FOR THE USE OF COATED ABRASIVES PRODUCTS

To find out about international and national legal Health & Safety requirements see Fepa (The Association of European manufacturers of abrasive products) website [www.fepa-abrasives.org](http://www.fepa-abrasives.org) and BAF (British Abrasives Federation) [www.thebaf.org.uk](http://www.thebaf.org.uk)

### Short list of main legal recommendations:

- 1. Carry out risk assessment**  
Only use abrasives which conform to European safety standards. Make sure your abrasives are supplied with FEPA safety information. Train operators.
- 2. Observe rules for personal protection (PPA) Directive 89/686/EEC**  
Gloves, safety goggles, ear defenders, dust masks).
- 3. Noise**  
Abrasive belts do not create noise. Noise comes mainly from contact wheels, work pieces  
Or poorly maintained machines
- 4. Dust**  
All abrasive belt operations create dust which has to be captured and collected. Efficient dust capture can only be achieved with properly designed guards/dust hoods. The choice of dust extractors depends on the type of dust. Some dusts are hazardous and can cause fire and/or explosions. Some dusts present personal hazards. Ask for advice.
- 5. Vibrations**  
Vibration comes mainly from contact wheels and/or work pieces, not from abrasive belts.  
Poor maintenance can add to levels of vibrations.
- 6. Disposal**  
Dispose of used abrasive belts and dust in accordance with local and national regulations.

### Main causes of injuries:

- Lack of personal protection
- Bodily contact with abrasives
- Incorrect point of contact between abrasive belt and work piece. (correct position is just below centre line of contact wheel)
- Unsuitable machine guarding
- Stupidity
- Lack of suitable training
- Unsuitable dust extraction
- Poor machine maintenance
- Non observance of max. cutting speeds
- Static electricity
- Faulty abrasive products





Introducing the largest and most advanced range of  
**DEBURRING • GRAINING • FINISHING • POLISHING**

Machines, Tools, Accessories and Consumables for Sheet Metal Engineers • Sheet & Plate Fabricators • Profilers • Steel Centres



Traditional wide belt machines from 600 - 1500mm working widths



Newly designed dedicated machines for deburring, corner rounding and oxide removal



Narrow belt throughfeed machines



Single and multi-head tube polishers



Portable abrasive wheel power tools



Single and twin long belt finishing machines



For the  
 Largest range of  
 ABRASIVE GRINDING,  
 DEBURRING AND  
 POLISHING MACHINES  
 IN THE UK



Portable belt files and tube finishing tools



Sheet mirror polishing machines



CLICK ON  
[www.surtech.co.uk](http://www.surtech.co.uk)  
 or ring  
 0121 359 4322



Belt Grinders



Dust extractors Dry and wet



Portable and automatic bevelling machines



Straight and bent tube polishing machines



Weld Cleaning tools



Manual sheet Deburrers



Pneumatic, expanding & standard contact wheels



Polishing mops and compo



Graining, finishing and polishing wheels



Narrow and wide abrasive belts for all applications

